

General Catalogue

mäder
pressen



Manual presses

Pneumatic presses

Hydropneumatic presses

Contents

mäder, the company	3
Press-Workstations	4
Special designs	5
Manual presses	
■ Accessories for manual presses	7
■ Toggle presses with round ram	8-11
■ Toggle presses with square ram	12-15
■ Rack and pinion presses with round ram	16-17
■ Rack and pinion presses with square ram	18-19
Pneumatic presses	
■ Pneumatic toggle presses	20-23
■ Manually assisted pneumatic toggle presses	24-25
■ Direct acting pneumatic presses	26-37
■ Direct acting press cylinders	38-39
■ MicroPress® with square ram	40-41
■ Hydropneumatic presses	42-45
Slide tables	46
Standard controllers	47
Process monitoring TPC	48-49
Press & Tool Concept	50
■ Press/tool overview	51
■ KP 2.1 Hand-operated toggle presses	52-53
■ KP 3.1 Pneumatic presses	54-55
■ Tool systems	56-59

mäder presses, the applications

A number of processes can be performed quickly, precisely and easily with mäder presses.

For example:

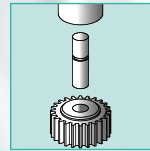

Assembly

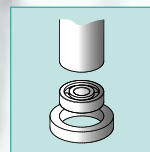

Pressing

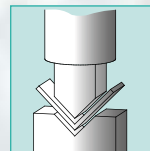

Bending

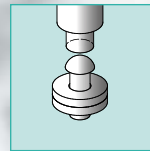

Riveting

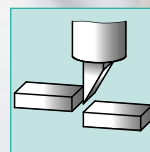

Edge cutting

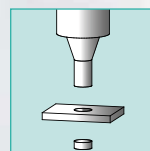

Punching

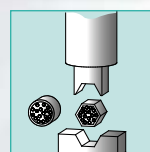

Crimping



As a medium-sized company, **mäder pressen** has been manufacturing manual and pneumatic table presses since the middle of the 1960s and from the very beginning has been a watchword for innovation, flexibility and reliability. Today, modern assembly presses are produced with high quality in our factory by qualified staff.

mäder pressen are active throughout the world and are represented in many countries with their own staff, agencies and partners.

mäder, the products

mäder presses are extensively used in all branches of the non-machining manufacturing industry. In particular in assembly, light engineering and electrical engineering and wherever precision and reliability are important. Special solutions represent a challenge for our team which we are only too pleased to accept.

Ultimately responsible for the high quality of the mäder press range are our qualified staff of many years standing, our in-depth manufacturing capability, and production on modern CNC machining centres.

Our presses are manufactured in accordance with the relevant EN norms. The controllers are type-tested by TÜV Süd in accordance with the latest issue of the EC Machinery Directive 2006/42/EC and are therefore CE compliant.

All these factors enable the quality of our products to be extensively monitored and are a decisive factor in helping our customers to success.

With a combination of different press components and equipment options, **mäder** presses always provide excellent value for money. In this way, mäder presses enable high flexibility and efficiency in production.

Ongoing development of our products also guarantees our customers a path to the future. Detailed improvements which increase both the technical quality and ergonomics of our presses continuously flow into our current production. New designs reflecting our customers' requirements are regularly introduced.

Special designs and customer-specific modifications of existing models can often be provided on request.

Contact us for more information.

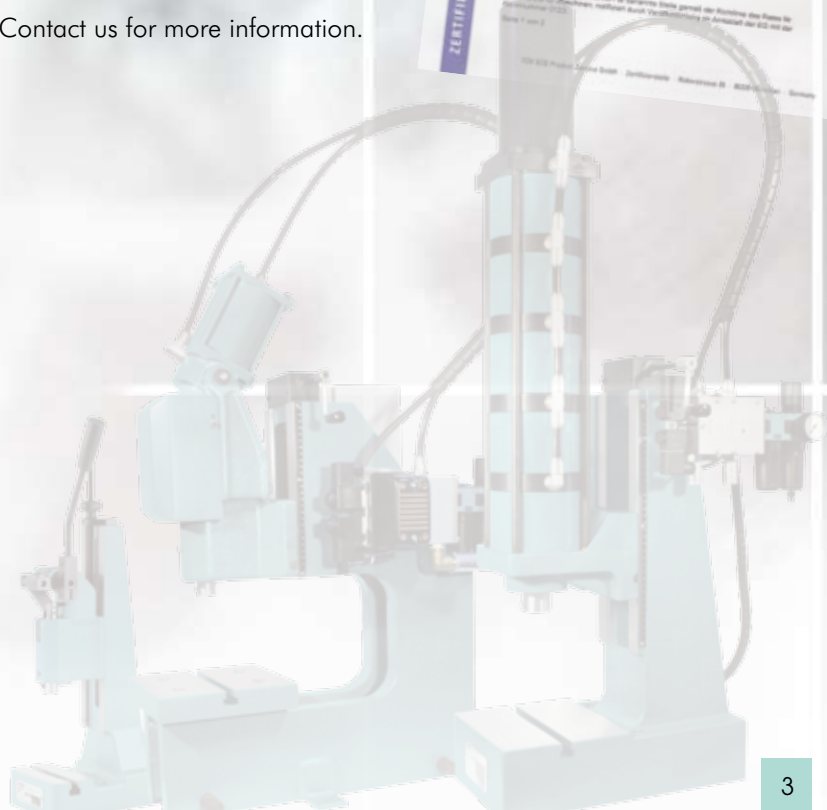

As well as presses, **mäder** also offers the design and construction of complete workstations. **mäder** presses are therefore able to satisfy today's requirements for flexible working means which can be quickly adapted to suit an ever increasing range of models in smaller batches and with shorter production cycles.

Flexible manual workstations which are designed to customers' requirements mean a reasonable investment. Our pictures of practical applications show some of the many possible solutions.



Colours

- Standard colour RAL 5021 or RAL 7035 on request at no extra cost
- Special RAL colours at extra cost



RAL 5021

RAL 7035

Special colour

Special models

In spite of the large number of standard presses, there are applications where it is necessary to modify existing models in order to optimise the manufacturing process or to make manufacturing possible at all. **mader presses** design and produce these special models in agreement with you.

- Cleanroom models in different designs to customers' specifications
- Extended daylight or throat
- User-specific special functions



Example: Cleanroom design
Cast parts chemically nickel-plated, other parts stainless steel

A small selection of modified presses



Capacity range: from 1.5 kN to 30 kN

Manual presses provide great economy for production processes and batch sizes which require no automation. They can be used quickly and flexibly in such applications.

mäder produces two types of manual presses with different force characteristics: Toggle presses and rack and pinion presses. All **mäder** manual presses can be provided with round or square rams.

Quality features

- Factory-set pressure point
- Simple and rapid adjustment of the height of the press head using a threaded spindle
- Hardened and ground ram
- Long, honed and therefore high-precision round ram guide
- High-accuracy square ram guide by means of adjustable jib strips
- Ground press table
- **mäder** manual presses are virtually maintenance-free

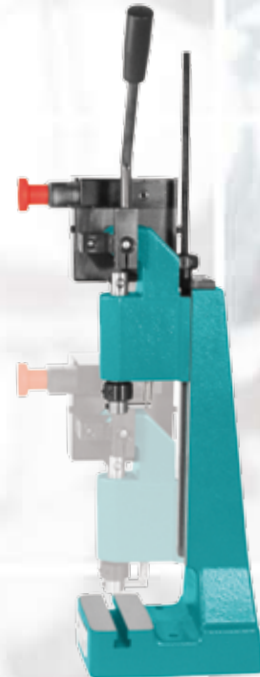

Example: Height-adjustable press head



Example: Rack and pinion press



Example: Toggle press

Pictograms in the catalogue show which accessories are possible for which presses.

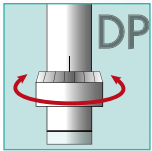

Precision ram adjustment (DP)

As toggle presses do not achieve their maximum force until BDC, adjusting the height of the press head by means of the threaded spindle is often too inaccurate. The precision ram adjustment enables the press pressure point to be precisely set directly at the ram. The scale on the adjustment ring enables the fine setting to be read off to 0.02 mm. The adjustment range is ± 1.5 mm. The precision ram adjustment is used when the utmost precision is required for the press depth. Ideal for prototype manufacture and serial production when accurate and easy adjustment within the tolerance range is required.



Micrometer stop (MICRO)

The micrometer stop is used with rack and pinion presses for high-precision assembly work or for when the tool has to be accurately positioned. This enables the press stroke length to be accurately adjusted to 0.01 mm.

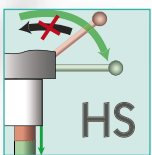

Return travel lock (HS)

The return travel lock for toggle and rack and pinion presses is an effective contribution to quality assurance during production. The return travel lock rules out partial strokes and therefore incomplete operations. Forming, assembly and joining operations are always reliably and completely executed, as the return stroke of the press is blocked on the downward stroke. The interlock is only released and the lever can only be returned when the stroke is complete. The Quick-Release mechanism enables this inhibit to be released and jammed parts to be removed in any position. The Quick-Release is automatically deactivated when the lever is returned.

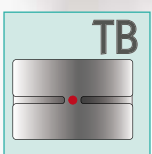
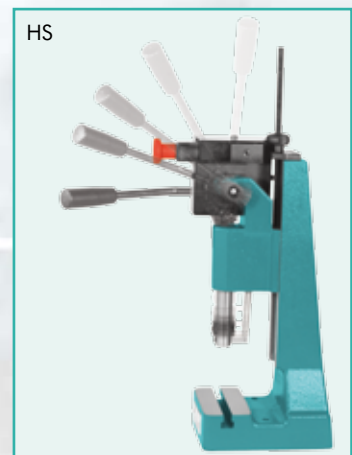
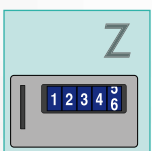

Table bore (TB)

The bottom part of the tool can be mounted in the centric table bore. Fixing is by means of a transverse screw in all models up to 80 mm throat. The table bore enables the tool to be changed quickly and reduces set-up time. The alignment accuracy of the ram bore with the table bore is < 0.05 mm.



stroke counter (Z)

A rapid overview of the number of items produced can be obtained with the five-digit stroke counter. The number of items can be reset.



The accessories

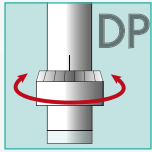

Manual toggle presses with round ram EP range

EP Type toggle presses in 5 kN, 7.5 kN and 12 kN sizes are designed for serial or individual manufacture in manual workstations. As the nominal end force is produced at the end of the stroke, a large force can be exerted at the exact point it is required. The manual force of 120 N to be applied is user-friendly. As many applications require less force, fatigue-free working is possible even with serial production.

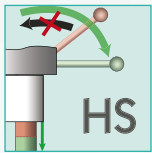

ERGOPRESS® hand lever

- Ergonomic user comfort.
- 360° stepless adjustment
- Lever angled to the side: free view of work area and ergonomically comfortable position.
- Simple and easy conversion for left-handers (except HS and Z option) without losing the tool setting. Ideal for job sharing on one press.

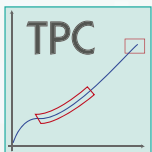
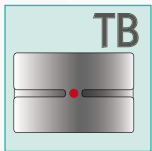
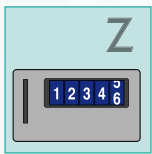

EP type presses are modern production tools with high precision. The user-friendly design increases productivity and prevents forced and abnormal postures of the operator due to the workplace.

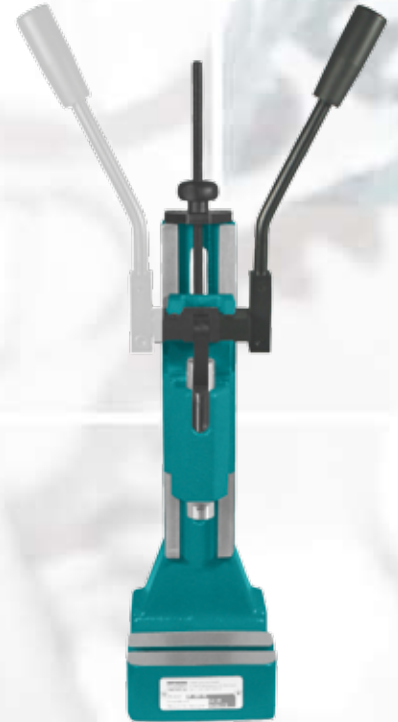

Manual lever can be refitted for right and left-handers

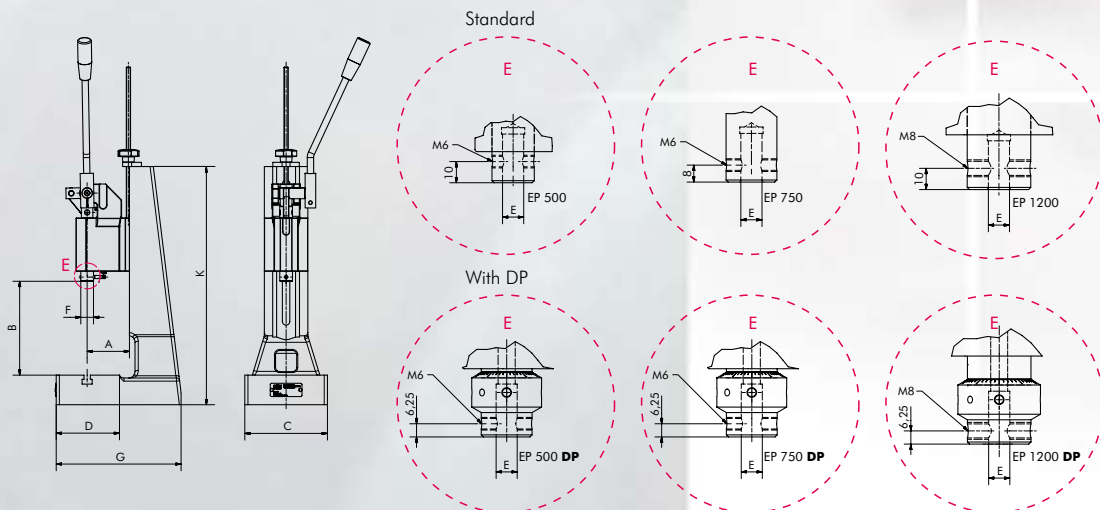
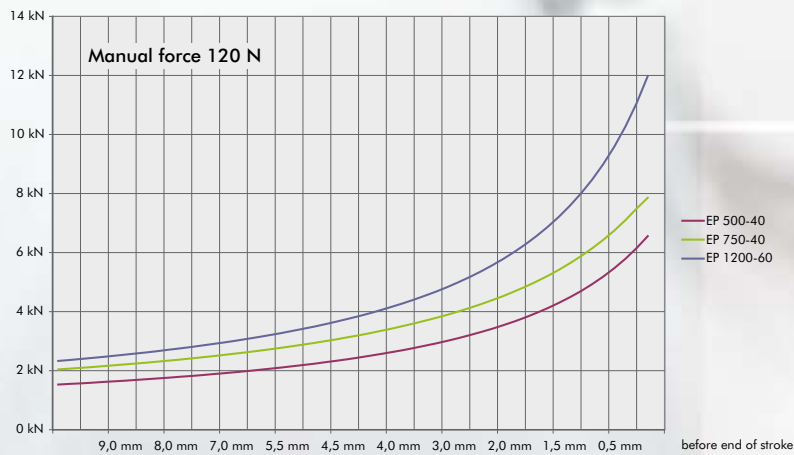

EP range
L-EP range with extra large daylight



EP 500-40

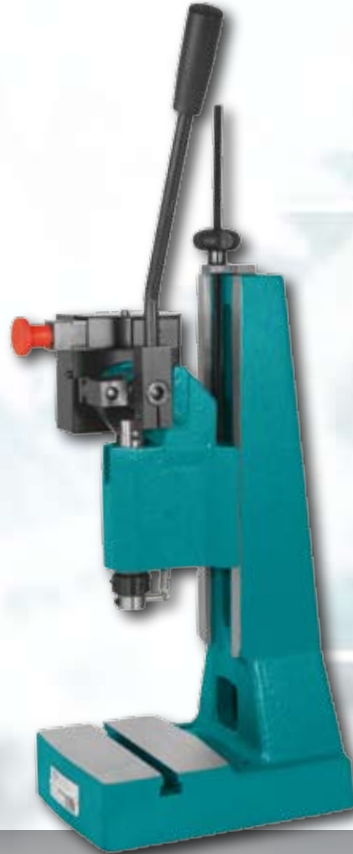

EP 750-40

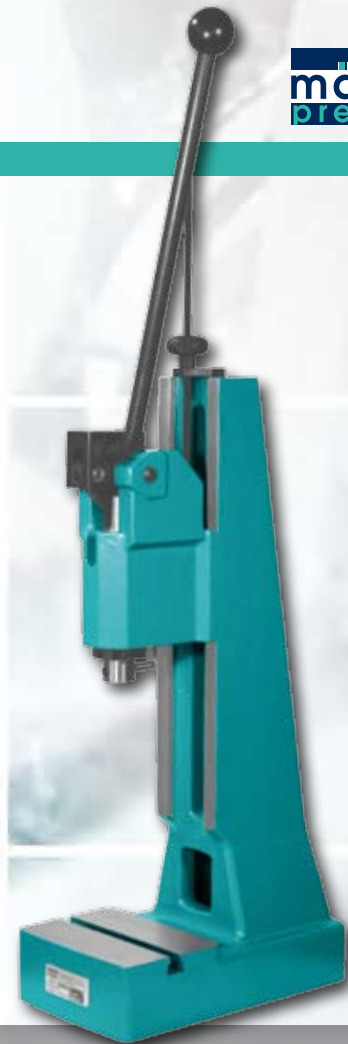

L-EP 1200-60

with accessories
DP - Precision ram adjustment
HS - Return travel lock

essera elppogToggle presses

Type			EP 500-40	EP 750-40	L-EP 750-40	EP 1200-60	L-EP 1200-60
Capacity		kN	5,0	7,5	7,5	12,0	12,0
Working stroke		mm	40	40	40	60	60
Throat	A	mm	63	80	80	80	80
Daylight	B	mm	40 - 213	58 - 265	55 - 375	62 - 240	75 - 338
Daylight with DP	B	mm	20 - 197	38 - 250	39 - 359	48 - 231	53 - 328
Table size	CxD	mm	110 x 65	157 x 115	157 x 115	157 x 115	157 x 115
T-slot width similar to DIN 650		mm	10	12	12	12	12
Ram bore Ø x Depth	E	mm	10 ^{H7} x 25	10 ^{H7} x 25	10 ^{H7} x 25	10 ^{H7} x 30	10 ^{H7} x 30
Ram bore Ø x Depth with DP	E	mm	10 ^{H7} x 25	10 ^{H7} x 25	10 ^{H7} x 25	10 ^{H7} x 25	10 ^{H7} x 25
Ram Ø	F	mm	20	24	24	30	30
Space requirement	CxG	mm	110 x 164	157 x 237	157 x 280	157 x 237	157 x 280
Stand height	K	mm	355	450	570	450	570
Weight		kg	ca. 10	ca. 20	ca. 28	ca. 24	ca. 32

Accessories (see Page 7)	Please specify when ordering.				
Precision ram adjustment	DP	DP	DP	DP	DP
Return travel lock	HS	HS	HS	HS	HS
Counter	Z	Z	Z	Z	Z
Table bore 12 ^{H7}	TB	TB	TB	TB	TB

The accessories

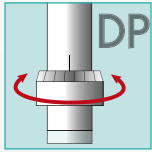

APK T-range

The extra powerful hand-operated toggle presses of the APK T 3 and APK T 4 ranges are especially suitable for the frequently changing applications in model making and in the workshop. Their high forces of up to 30 kN enable them to be flexibly used for widely differing applications.

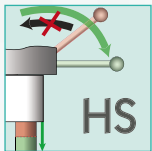

The advantages:

- Choice of different stroke lengths
- Extra stable press base design
- Daylight easily adjustable by means of the standard press head threaded spindle height adjustment
- The nominal force of the press can be achieved with moderate applied force

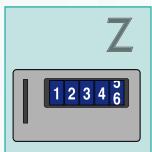

XL-APKT range with 250 mm throat

A larger throat is required wherever bulky parts are processed, e.g. the processing of printed circuit boards, sheet metal and similar parts. mäder XL presses with 250 mm throat are employed in such cases. The base is a stable welded structure to which different standard press heads can be fitted.

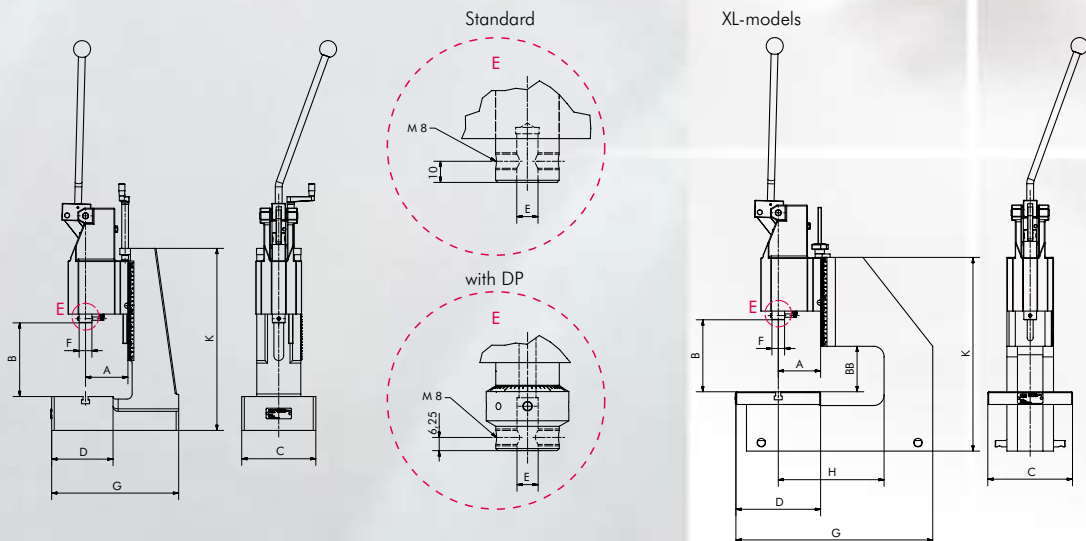
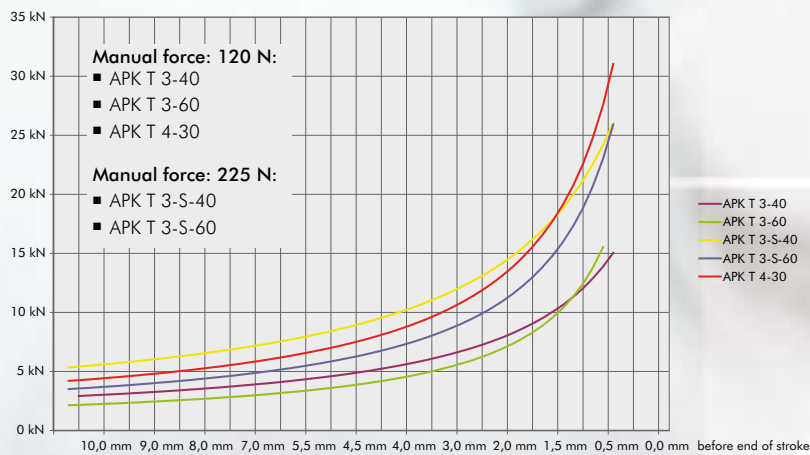
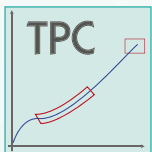
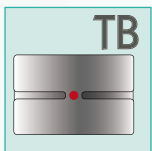

APK T range

XL-APK T range with 250 mm throat



APK T 3-40

APK T 3-S-60

XL-APK T 3-40

Toggle presses

Type			APK T3-40	APK T3-60	APK T3-S-40	APK T3-S-60	APK T4-30	XL-APK T3-40	XL-APK T3-60
Capacity		kN	15,0	15,0	25,0	25,0	30,0	15,0	15,0
Working stroke		mm	40	60	40	60	30	40	60
Throat	A	mm	100	100	100	100	100	250	250
Throat C-frame	H	mm	-	-	-	-	-	100	100
Daylight	B	mm	49 - 168	51 - 172	60 - 290	65 - 295	55 - 285	88 - 166	90 - 168
Daylight with DP	B	mm	35 - 154	30 - 151	46 - 274	44 - 274	34 - 264	72 - 150	69 - 147
Daylight C-frame	BB	mm	-	-	-	-	-	100	100
Table size	CxD	mm	175 x 140	175 x 140	185 x 145	185 x 145	185 x 145	200 x 200	200 x 200
T-slot width similar to DIN 650		mm	12	12	12	12	12	12	12
Ram bore Ø x Depth	E	mm	10 ^{H7} x 30	10 ^{H7} x 30	10 ^{H7} x 30	10 ^{H7} x 30	10 ^{H7} x 30	10 ^{H7} x 30	10 ^{H7} x 30
Ram bore Ø x Depth with DP			10 ^{H7} x 25	10 ^{H7} x 25	10 ^{H7} x 25	10 ^{H7} x 25	10 ^{H7} x 25	10 ^{H7} x 25	10 ^{H7} x 25
Ram Ø	F	mm	30	30	30	30	30	30	30
Space requirement	CxG	mm	175 x 300	175 x 300	185 x 320	185 x 320	185 x 320	200 x 465	200 x 465
Stand height	K	mm	425	425	520	520	520	465	465
Weight		kg	ca. 39	ca. 43	ca. 58	ca. 63	ca. 63	ca. 54	ca. 58

Accessories (see Page 7)	Please specify when ordering.							
Precision ram adjustment	DP	DP	DP	DP	DP	DP	DP	DP
Return travel lock	HS	HS	HS	HS	HS	HS	HS	HS
Counter	Z	Z	Z	Z	Z	Z	Z	Z
Table bore 12 ^{H7}	TB	TB	TB	TB	TB	TB	TB	TB

The accessories

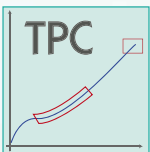
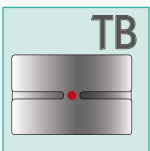
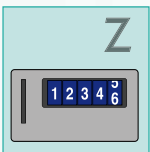
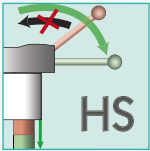
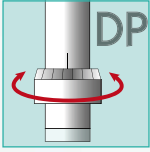

The square ram has significant advantages compared with the round ram:

- Absolute protection against twisting
- Hardened and precisely ground ram
- Press ram guide free from play
- Readjustable jib strips for square ram
- Large tool locating surface
- Guides in tool therefore usually unnecessary
- Practically maintenance-free operation

mäder hand-operated toggle presses with square ram are ideal tools for manufacturing small precision parts with tight tolerances in small and medium-sized batches where automation would be too cost intensive.

ERGOPRESS® hand lever

- Ergonomic user comfort.
- 360° stepless adjustment
- Lever angled to the side: free view of work area and ergonomically comfortable position.
- Simple and easy conversion for left-handers (except HS and Z option) without losing the tool setting. Ideal for job sharing on one press.

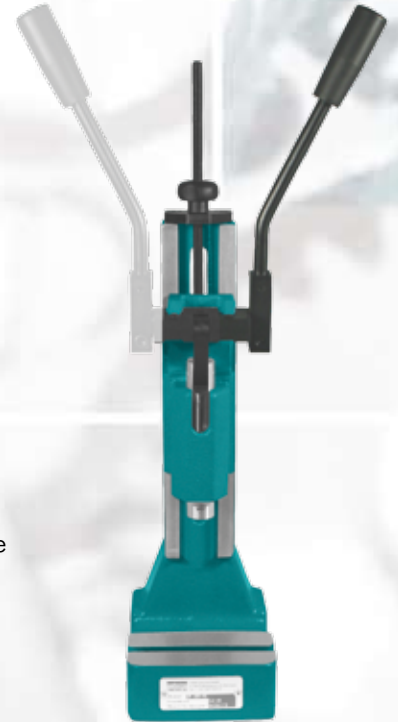

Manual lever can be refitted for right and left-handers

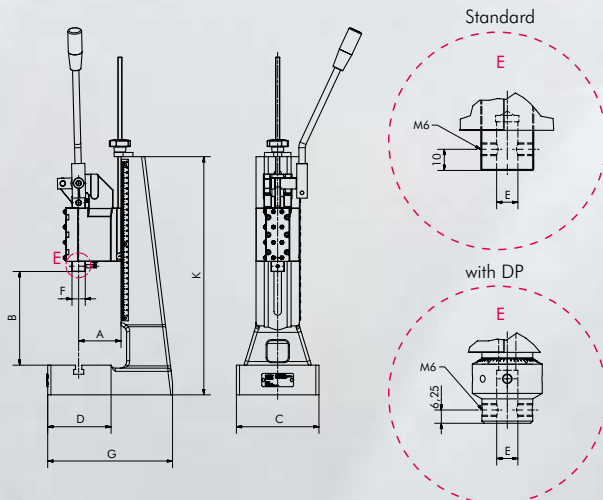
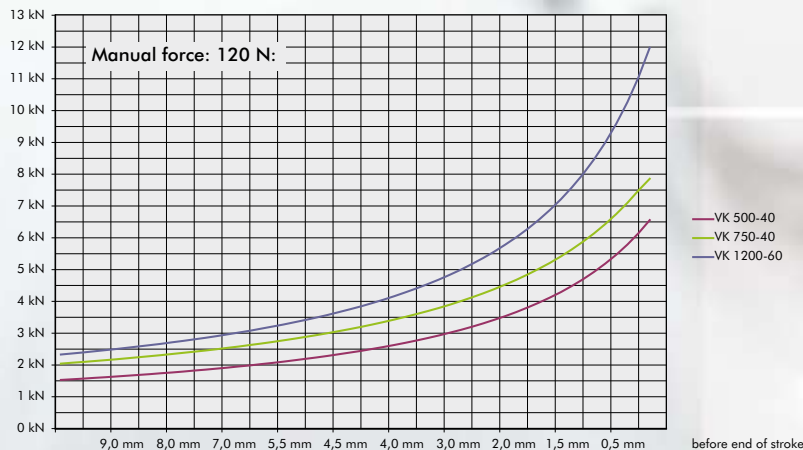

VK range
L-VK range with extra large daylight

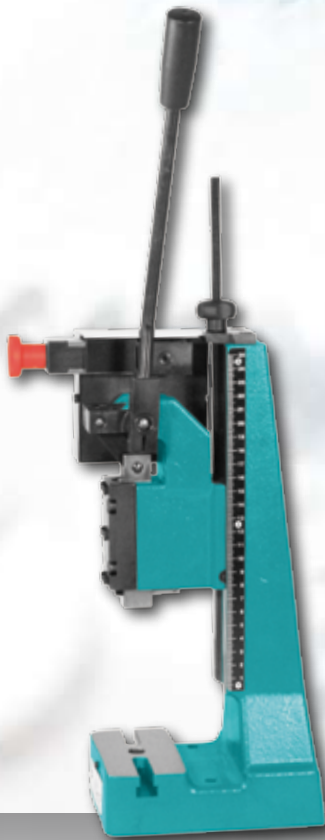

VK 500-40

with accessory HS - Return travel lock



L-VK 750-40



L-VK 1200

Toggle presses

Type			VK 500-40	VK 750-40	L-VK 750-40	VK 1200-60	L-VK 1200-60
Capacity		kN	5,0	7,5	7,5	12,0	12,0
Working stroke		mm	40	40	40	60	60
Throat	A	mm	63	80	80	80	80
Daylight	B	mm	40 - 213	53 - 265	55 - 375	45 - 245	52 - 352
Daylight with DP	B	mm	25 - 197	38 - 250	39 - 359	31 - 231	38 - 338
Table size	CxD	mm	110 x 65	157 x 115	157 x 115	157 x 115	157 x 115
T-slot width similar to DIN 650		mm	10	12	12	12	12
Ram bore Ø x Depth	E	mm	10 ^{H7} x 25	10 ^{H7} x 25	10 ^{H7} x 25	10 ^{H7} x 30	10 ^{H7} x 30
Ram bore Ø x Depth with DP	E	mm	10 ^{H7} x 25	10 ^{H7} x 25	10 ^{H7} x 25	10 ^{H7} x 25	10 ^{H7} x 25
Ram area	F	mm	21 x 21	25 x 25	25 x 25	31 x 31	31 x 31
Space requirement	CxG	mm	110 x 164	155 x 237	155 x 280	155 x 237	155 x 280
Stand height		mm	355	450	570	450	570
Weight		kg	ca. 10	ca. 20	ca. 28	ca. 24	ca. 32

Accessories (see Page 7)	Please specify when ordering.				
Precision ram adjustment	DP	DP	DP	DP	DP
Return travel lock	HS	HS	HS	HS	HS
Counter	Z	Z	Z	Z	Z
Table bore 12 ^{H7}	TB	TB	TB	TB	TB

The accessories

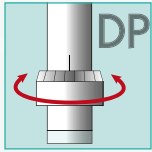

VK-range

The extra powerful hand-operated toggle presses of the VK range are especially suitable for the frequently changing applications in model making and in the workshop. Their high forces of up to 30 kN enable them to be flexibly used for widely differing applications.

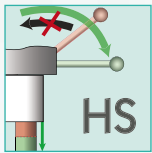

The advantages:

- Choice of different stroke lengths
- Extra stable press base design
- Daylight easily adjustable by means of the standard press head threaded spindle height adjustment
- The nominal force of the press can be achieved with moderate applied force

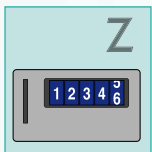

XL-VK range with 250 mm throat

A larger throat is required wherever bulky parts are processed, e.g. the processing of printed circuit boards, sheet metal and similar parts. mäder XL presses with 250 mm throat are employed in such cases. The base is a stable welded structure to which different standard press heads can be fitted.

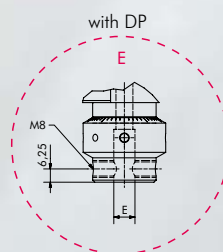
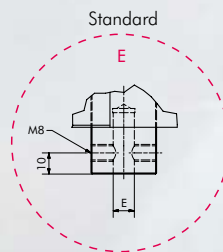
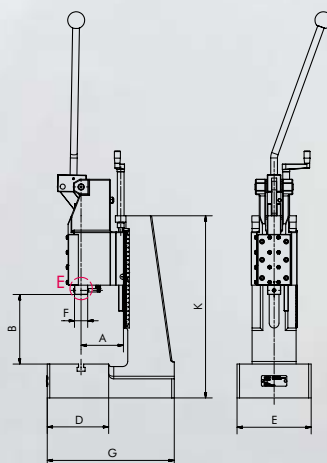
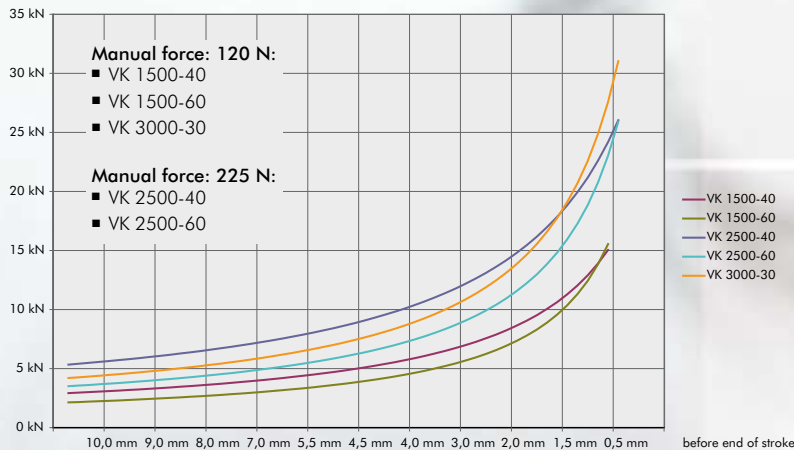
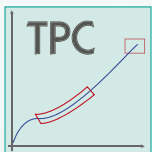
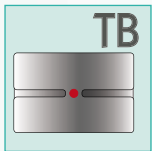

XL-models

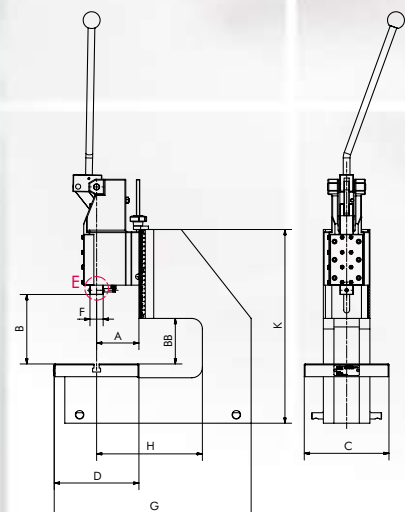

VK range
XL-VK range with 250 mm throat



VK 1500-40

VK 2500-60

XL-VK 1500-40

Type			VK 1500-40	VK 1500-60	VK 2500-40	VK 2500-60	VK 3000-30	XL-VK 1500-40	XL-VK 1500-60
Capacity		kN	15,0	15,0	25,0	25,0	30,0	15,0	15,0
Working stroke		mm	40	60	40	60	30	40	60
Throat	A	mm	100	100	100	100	100	250	250
Throat C-frame	H	mm	-	-	-	-	-	100	100
Daylight	B	mm	49 - 168	49 - 168	60 - 290	65 - 295	65 - 295	80 - 166	88 - 166
Daylight with DP	B	mm	35 - 154	35 - 154	46 - 274	44 - 274	44 - 274	72 - 150	72 - 150
Daylight C-frame	BB	mm	-	-	-	-	-	100	100
Table size	CxD	mm	175 x 140	175 x 140	185 x 145	185 x 145	185 x 145	200 x 200	200 x 200
T-slot width similar to DIN 650		mm	12	12	12	12	12	12	12
Ram bore Ø x Depth	E	mm	10 ^{H7} x 30	10 ^{H7} x 30	10 ^{H7} x 30	10 ^{H7} x 30	10 ^{H7} x 30	10 ^{H7} x 30	10 ^{H7} x 30
Ram bore Ø x Depth with DP	E	mm	10 ^{H7} x 25	10 ^{H7} x 25	10 ^{H7} x 25	10 ^{H7} x 25	10 ^{H7} x 25	10 ^{H7} x 25	10 ^{H7} x 25
Ram area	F	mm	31 x 31	31 x 31	31 x 31	31 x 31	31 x 31	31 x 31	31 x 31
Space requirement	CxG	mm	175 x 300	175 x 300	185 x 320	185 x 320	185 x 320	200 x 465	200 x 465
Stand height	K	mm	425	425	520	520	520	465	465
Weight		kg	ca. 39	ca. 43	ca. 58	ca. 63	ca. 63	ca. 55	ca. 59

Accessories (see Page 7)	Please specify when ordering.							
Precision ram adjustment	DP	DP	DP	DP	DP	DP	DP	DP
Return travel lock	HS	HS	HS	HS	HS	HS	HS	HS
Counter	Z	Z	Z	Z	Z	Z	Z	Z
Table bore 12 ^{H7}	TB	TB	TB	TB	TB	TB	TB	TB

The accessories



APZ-Range, L-APZ Range with extra large daylight

mäder rack and pinion presses transmit their force constantly over the whole stroke length. The direct transmission of force via the manual lever allows fine control. Rack and pinion presses are therefore used where a constant force characteristic over a longer stroke is required.

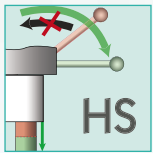

Manual lever with ergonomic user comfort

- Can be turned through 360°: Adaptable for any body size and application.
- Lever angled to the side: free view of work area and ergonomically comfortable position.
- **R/L Version:** Simple and easy conversion for left-handers without losing the tool setting. Ideal for job sharing on one press.

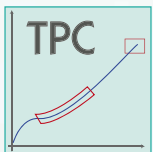
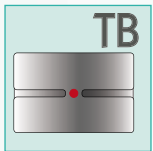
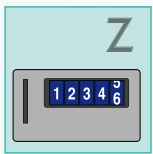

Left/right-hander version

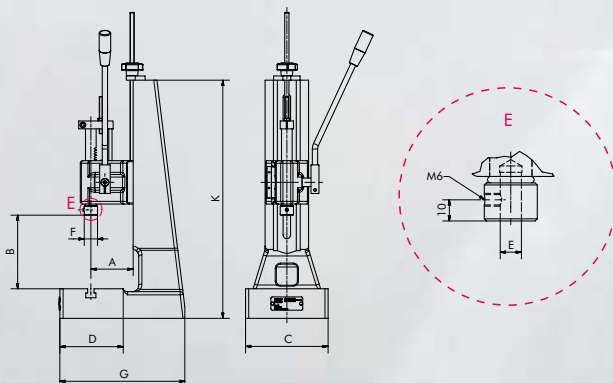

APZ range
L-APZ range with extra large daylight



APZ T 1-40



APZ T 2-50



L-APZ T 2-50

Type			APZ T1-40	APZ T1-90	APZ T2-50	APZ T2-100	L-APZ T2-50	L-APZ T2-100
Capacity		kN	1,5	1,5	2,5	2,5	2,5	2,5
Working stroke		mm	40	90	50	100	50	100
Throat	A	mm	63	63	80	80	80	80
Daylight	B	mm	40 - 235	40 - 235	42 - 290	42 - 290	55 - 390	55 - 390
Table size	CxD	mm	110 x 65	110 x 65	157 x 115	157 x 115	157 x 115	157 x 115
T-slot width similar to DIN 650		mm	10	10	12	12	12	12
Ram bore Ø x Depth	E	mm	10 ^{H7} x 25	10 ^{H7} x 25	10 ^{H7} x 25	10 ^{H7} x 25	10 ^{H7} x 25	10 ^{H7} x 25
Ram Ø	F	mm	25	25	25	25	25	25
Space requirement	CxG	mm	110 x 164	110 x 164	157 x 237	157 x 237	155 x 280	155 x 280
Stand height	K	mm	355	355	450	450	570	570
Weight		kg	ca. 8,5	ca. 8,5	ca. 21	ca. 21	ca. 29	ca. 29

Accessories (see Page 7)	Please specify when ordering.					
Return travel lock	HS	HS	HS	HS	HS	HS
Mikrometer	MICRO	MICRO	MICRO	MICRO	MICRO	MICRO
Counter	Z	Z	Z	Z	Z	Z
Table bore 12 ^{H7}	TB	TB	TB	TB	TB	TB
Left/right-hander version*	R/L	R/L	R/L	R/L	R/L	R/L

* Can only be combined with the MICRO and Z accessories.

The accessories

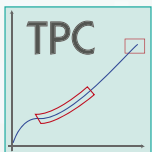
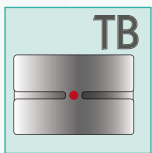
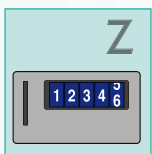
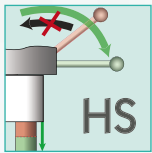

VZ-range, L-VZ range with extra large daylight

The square ram has significant advantages compared with the round ram:

- Absolute protection against twisting
- Press ram guide free from play
- Readjustable guide rails for square ram
- Large tool locating surface
- Guides in tool therefore usually unnecessary
- Practically maintenance-free operation

mäder rack and pinion presses with square ram are ideal tools for manufacturing small precision parts with tight tolerances in small and medium-sized batches where automation would be too cost intensive.

Manual lever with ergonomic user comfort

- Can be turned through 360°: Adaptable for any body size and application.
- Lever angled to the side: free view of work area and ergonomically comfortable position.
- **R/L Version:** Simple and easy conversion for left-handers without losing the tool setting. Ideal for job sharing on one press.



Left/right-hander version

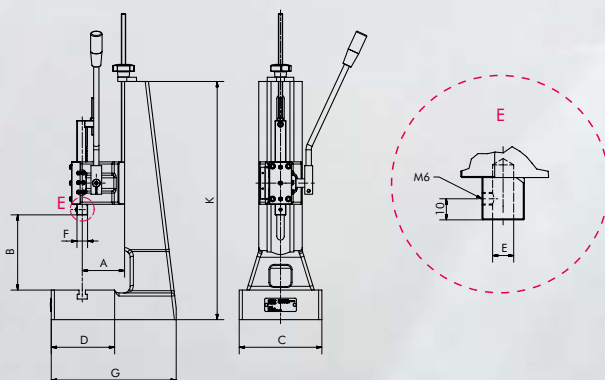

VZ range
L-VZ range with extra large daylight

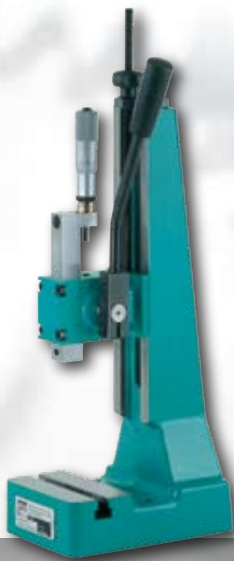

VZ 150-40

With MICRO accessory

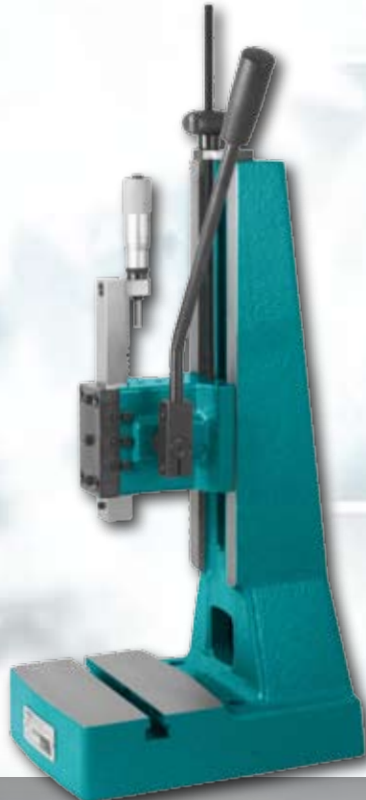

VZ 250-50

With MICRO accessory



L-VZ 250-50

Type			VZ 150-40	VZ 150-90	VZ 250-50	VZ 250-100	L-VZ 250-50	L-VZ 250-100
Capacity		kN	1,5	1,5	2,5	2,5	2,5	2,5
Working stroke		mm	40	90	50	100	50	100
Throat	A	mm	63	63	80	80	80	80
Daylight	B	mm	35 - 235	35 - 235	42 - 290	42 - 290	55 - 390	55 - 390
Table size	CxD	mm	110 x 65	110 x 65	157 x 115	157 x 115	157 x 115	157 x 115
T-slot width similar to DIN 650		mm	10	10	12	12	12	12
Ram bore Ø x Depth	E	mm	10 ^{H7} x 25	10 ^{H7} x 25	10 ^{H7} x 25	10 ^{H7} x 25	10 ^{H7} x 25	10 ^{H7} x 25
Ram area	F	mm	20 x 20	20 x 20	20 x 20	20 x 20	20 x 20	20 x 20
Space requirement	CxG	mm	110 x 164	110 x 164	157 x 237	157 x 237	155 x 280	155 x 280
Stand height	K	mm	355	355	450	450	570	570
Weight		kg	ca. 8,5	ca. 8,5	ca. 21	ca. 21	ca. 29	ca. 29

Accessories (see Page 7)	Please specify when ordering.						
Return travel lock	HS	HS	HS	HS	HS	HS	HS
Mikrometer	MICRO	MICRO	MICRO	MICRO	MICRO	MICRO	MICRO
Counter	Z	Z	Z	Z	Z	Z	Z
Table bore 12 ^{H7}	TB	TB	TB	TB	TB	TB	TB
Left/right hander Version*	R/L	R/L	R/L	R/L	R/L	R/L	R/L

* Can only be combined with the MICRO and Z accessories.

The accessories

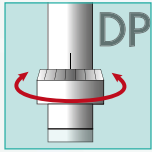

Pneumatic toggle presses APK*L and VKL range

The optimum transmission ratio of the toggle lever produces large forces at the end of the stroke and ensures low air consumption. The resulting low energy consumption means that **mäder** pneumatic toggle presses are a cost-effective production tool, not only at the procurement stage but also in the long term.

All pneumatic toggle presses can be provided with the standard **mäder** MPS-1 controller or with customer-specified controllers.

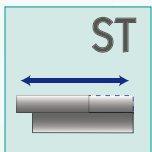
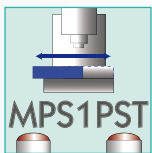
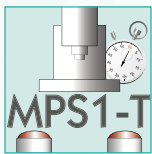
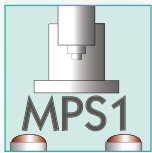

Other quality features:

- Factory pre-set pressure point
- Right-angled gearbox for simple height adjustment of the press head
- Side-mounted measuring strip for fast reproduction of settings when changing the tool
- Practically maintenance-free double-acting cylinder
- Low noise: less than 75 dB



Square ram

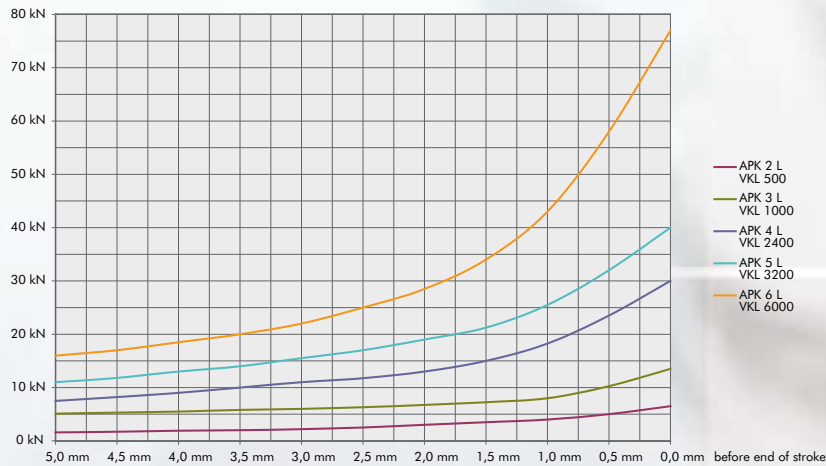

APK 2L
VKL 0500-35-80

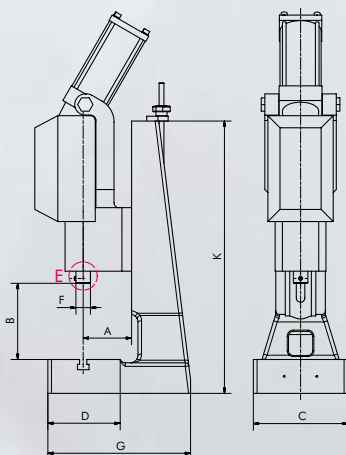

Standard

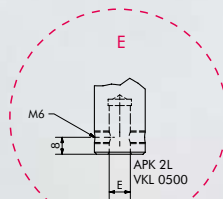

with DP

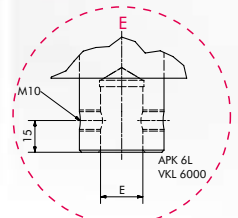
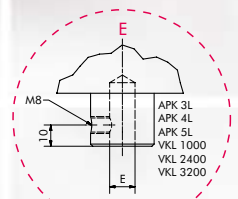
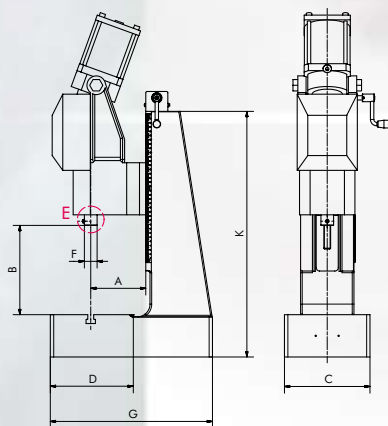
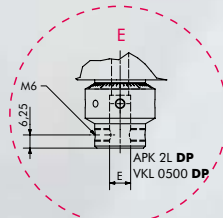

APK range with round ram
VKL range with square ram

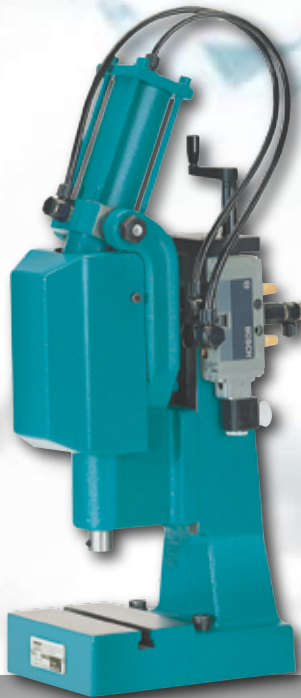

APK 2L

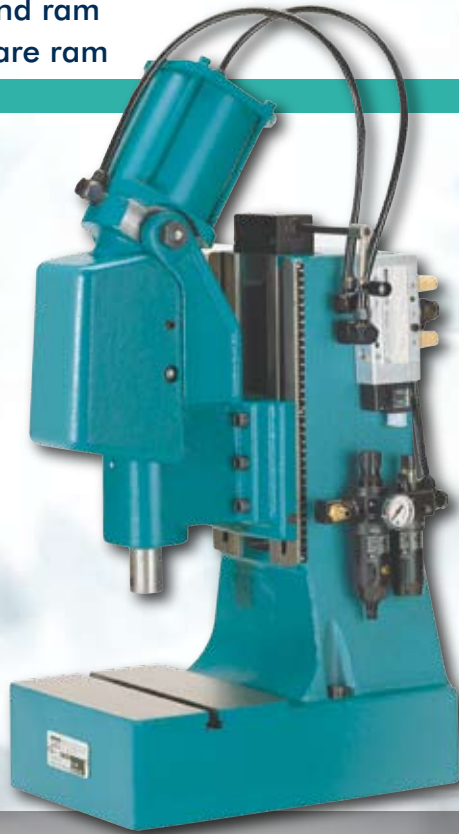

APK 6L

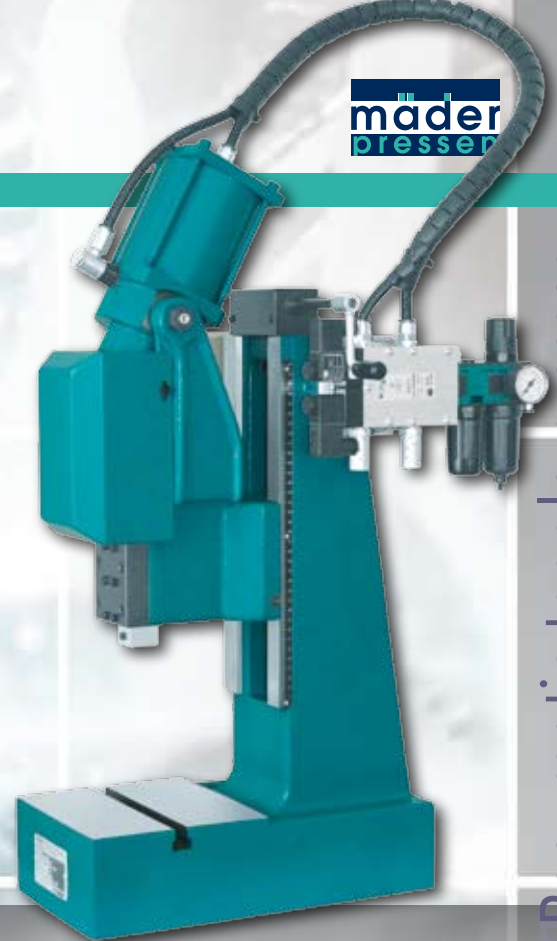

VKL 2400

Type			APK 2 L	APK 3 L	with round ram APK 4 L	APK 5 L	APK 6 L
Capacity		kN	5	10	24	32	60
Working stroke		mm	35	40	40	40	40
Throat	A	mm	80	100	130	130	150
Daylight	B	mm	80 - 265	110 - 280	175 - 330	175 - 330	87 - 310
Daylight with DP	B	mm	65 - 250	-	-	-	-
Table size	CxD	mm	157 - 115	185 - 145	200 x 190	200 x 190	300 x 210
T-slot width similar to DIN 650		mm	12	12	14	14	14
Ram bore Ø x Depth	E	mm	10 ^{H7} x 25	12 ^{H7} x 30	12 ^{H7} x 30	12 ^{H7} x 30	20 ^{H7} x 34
Ram Ø	F	mm	24	30	30	30	40
Port size			G 1/4"	G 1/4"	G 3/8"	G 3/8"	G 3/8"
Air consumption/cm cyl. stroke		l	0,26	0,41	1,05	1,05	1,65
Space requirement	CxG	mm	157 x 237	185 x 320	200 x 385	200 x 385	300 x 455
Stand height	K	mm	450	520	580	580	630
Weight		kg	ca. 22	ca. 55	ca. 95	ca. 96	ca. 140

Accessories (see Page 7)		Please specify when ordering				
Precision ram adjustment		DP	DP	-	-	-

Type			VKL 0500-35-80	VKL 1000-40-100	with square ram VKL 2400-40-130	VKL 3200-40-130	VKL 6000-40-150
Capacity		kN	5	10	24	32	60
Working stroke		mm	35	40	40	40	40
Throat	A	mm	80	100	130	130	150
Daylight	B	mm	80 - 265	110 - 280	175 - 330	175 - 330	90 - 320
Daylight with DP	B	mm	65 - 250	-	-	-	-
Table size	CxD	mm	157 x 115	185 x 145	200 x 190	200 x 190	300 x 210
T-slot width similar to DIN 650		mm	12	12	14	14	14
Ram bore Ø x Depth	E	mm	10 ^{H7} x 25	12 ^{H7} x 30	12 ^{H7} x 30	12 ^{H7} x 30	20 ^{H7} x 34
Ram area	F	mm	25 x 25	31 x 31	31 x 31	31 x 31	41 x 41
Port size			G 1/4"	G 1/4"	G 3/8"	G 3/8"	G 3/8"
Air consumption/cm cyl. stroke		l	0,26	0,41	1,05	1,05	1,65
Space requirement	CxG	mm	157 x 237	185 x 320	200 x 385	200 x 385	300 x 455
Stand height	K	mm	450	520	580	580	630
Weight		kg	ca. 22	ca. 55	ca. 95	ca. 96	ca. 140

Accessories (see Page 7)		Please specify when ordering.				
Precision ram adjustment		DP	DP	-	-	-

Valve and service unit only included with controller. Design may vary.

The accessories

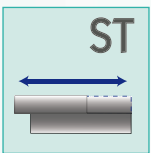
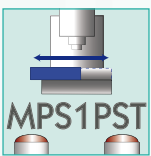
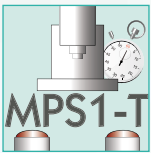
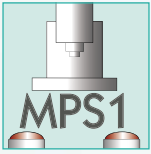

Pneumatic toggle presses XL-APK*L and XL-VKL range

Presses with XL throat are designed for processing large and bulky parts. The press stand consists of a stable welded structure which can be modified to suit customers' requirements. XL pneumatic toggle presses can be provided with the standard **mäder** MPS-1 controller or with customer specified controllers.

Other quality features:

- Factory pre-set pressure point
- Right-angled gearbox for simple height adjustment of the press head
- Side-mounted measuring strip for fast reproduction of settings when changing the tool
- Practically maintenance-free double-acting cylinder
- Low noise: less than 75 dB

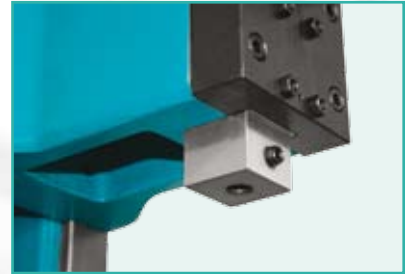

Square ram

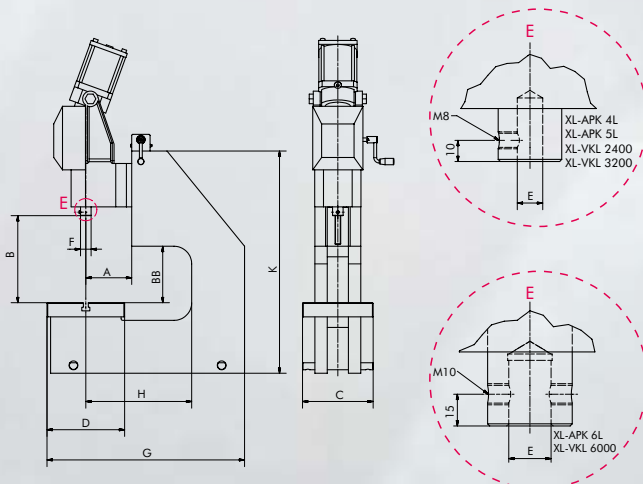
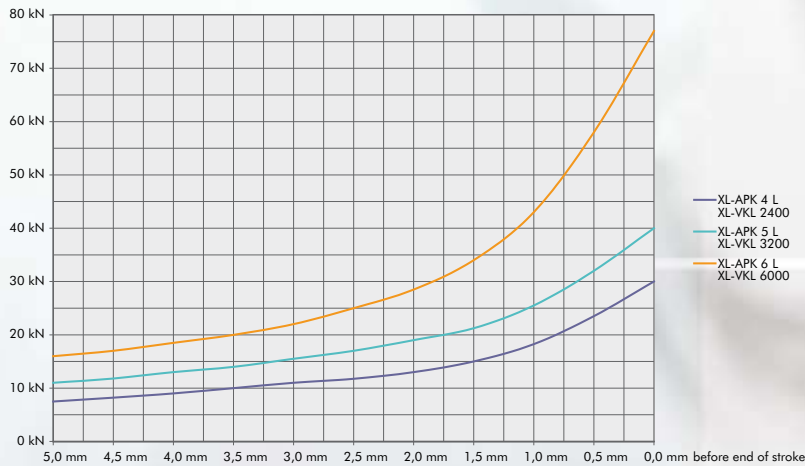

XL-APK range with round ram with 300 mm throat
 XL-VKL range with square ram with 300 mm throat



XL-APK 4L

Type	with round ram			with square ram			
		XL-APK 4 L	XL-APK 5 L	XL-APK 6L	XL-VKL 2400-40-300	XL-VKL 3200-40-300	XL-VKL 6000-40-300
Capacity	kN	24	32	60	24	32	60
Working stroke	mm	40	40	40	40	40	40
Throat	A mm	130	130	150	130	130	150
Throat C-frame	H mm	300	300	300	300	300	300
Daylight	B mm	130 - 280	130 - 280	130 - 230	130 - 280	130 - 280	130 - 230
Daylight C-frame	BB mm	158	158	190	158	158	190
Table size	CxD mm	200 x 220	200 x 220	310 x 220	200 x 220	200 x 220	310 x 220
T-slot width similar to DIN 650	mm	14	14	16	14	14	16
Ram bore Ø x Depth	E mm	12 ^{H7} x 30	12 ^{H7} x 30	20 ^{H7} x 34	12 ^{H7} x 30	12 ^{H7} x 30	20 ^{H7} x 34
Ram Ø / Ram area	F mm	30	30	40	31 x 31	31 x 31	41 x 41
Port size		G 3/8"	G 3/8"	G 3/8"	G 3/8"	G 3/8"	G 3/8"
Air consumption/cm cyl. stroke	l	1,05	1,05	1,65	1,05	1,05	1,65
Space requirement	CxG mm	200 x 560	200 x 560	320 x 610	200 x 560	200 x 560	320 x 610
Stand height	K mm	630	630	630	630	630	630
Weight	kg	ca. 149	ca. 150	ca. 250	ca. 149	ca. 150	ca. 250

Valve and service unit only included with controller. Design may vary.

The accessories

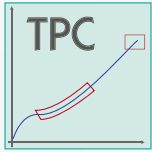

Manually assisted pneumatic toggle presses

Manually assisted toggle presses are used when, due to particular features of the workpiece, both hands cannot be engaged in two-handed operation at the beginning of the working stroke and a large force still has to be achieved at the end of the stroke. With the NP manually assisted pneumatic toggle presses, safe working is possible in such cases. The ram is lowered to the power stroke position using the manual lever and the workpiece is then held by the force of the lever. A sensor registers this position. At the same time, the workpiece can be released and a push button pressed with the second hand which then initiates the power stroke. The power stroke can only be initiated when both hands are engaged. Hence, if the manual lever were released, for example, the ram would be raised by a safety mechanism and the permission for the power stroke in the controller would thus be removed. The length of the pneumatic power stroke of NP manually assisted pneumatic toggle presses and therefore the TDC position can be steplessly adjusted with high precision from 0 mm - 6 mm stroke length using the standard fine adjustment facility. As a result of the special transmission mechanism, a constant power stroke is available over the whole length of the stroke.



Fine adjustment of pneumatic power stroke

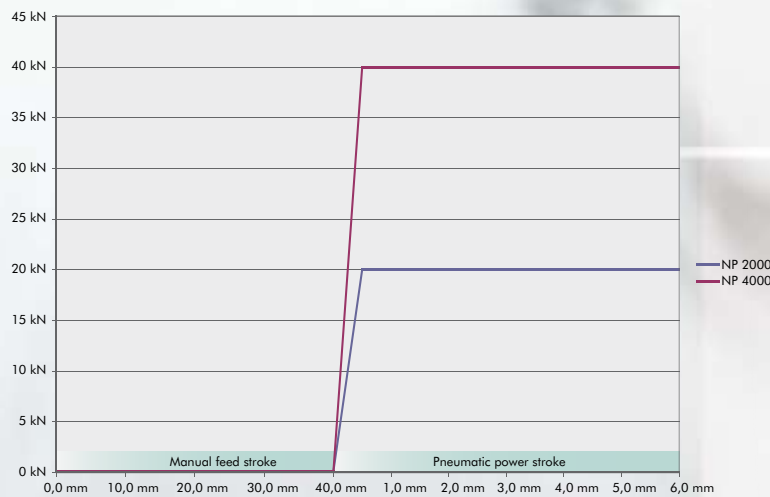

Complete unit

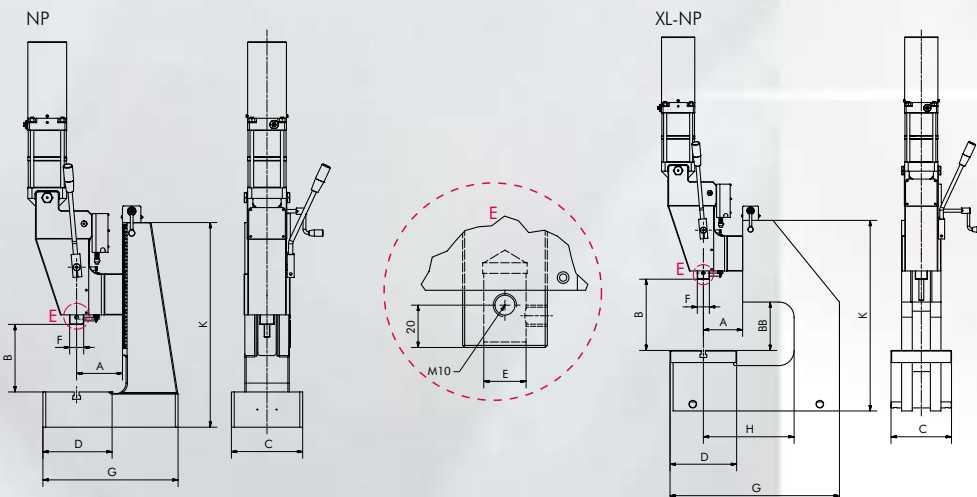

NP range
XL-NP range with 300 mm throat

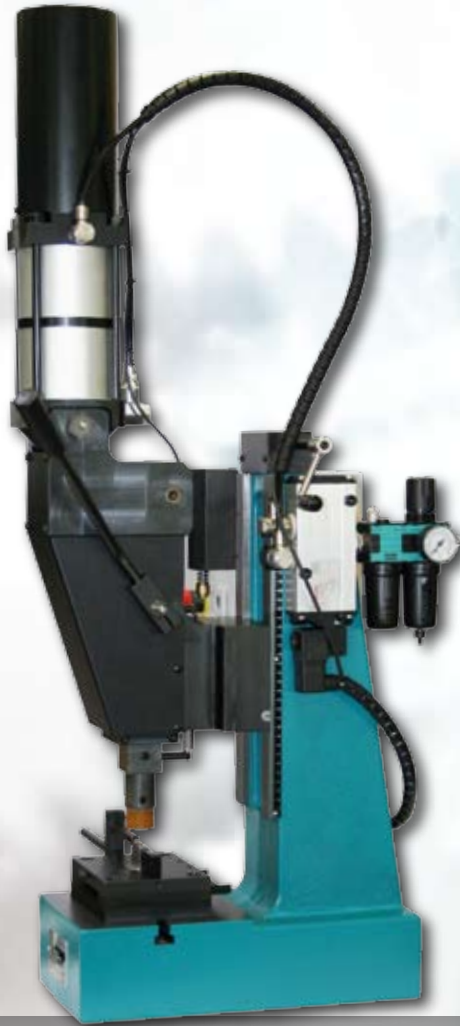

NP 4000

with punching tool

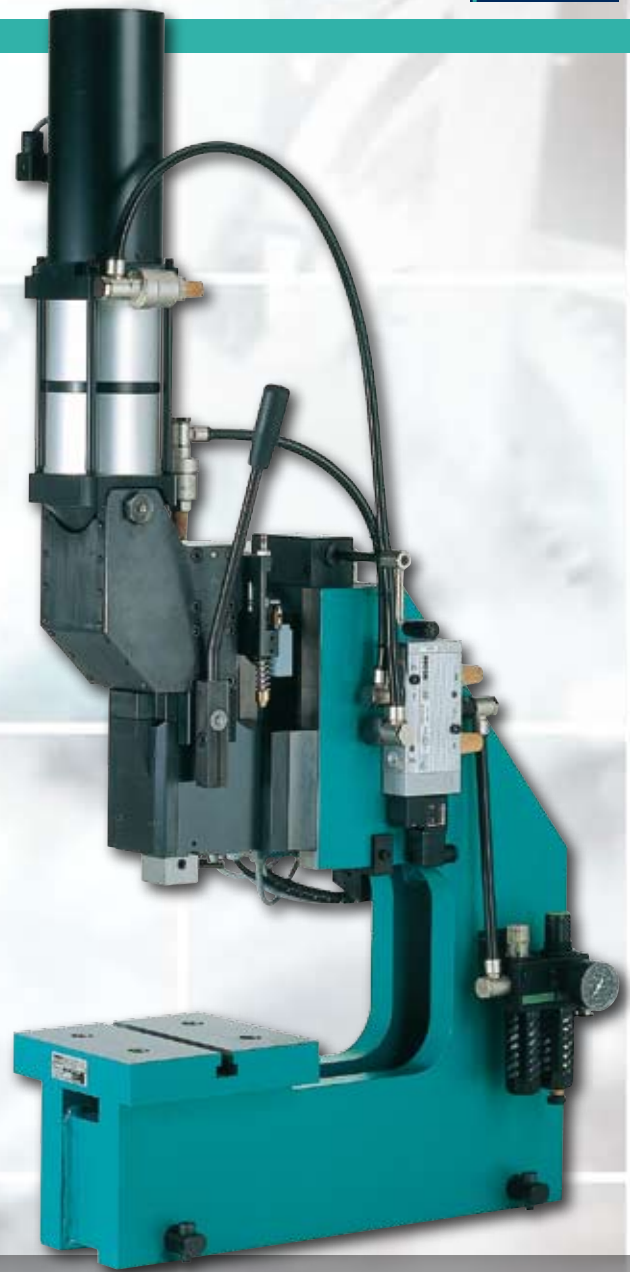

XL-NP 4000

Type			NP 2000	NP 4000	XL-NP 2000	XL-NP 4000
Capacity		kN	20	40	20	40
Manual feed stroke		mm	40	40	40	40
Pneumatic power stroke		mm	0 - 6	0 - 6	0 - 6	0 - 6
Throat	A	mm	130	130	130	130
Throat C-frame	H	mm	-	-	300	300
Daylight	B	mm	58 - 325	58 - 325	125 - 265	125 - 265
Daylight C-frame	BB	mm	-	-	158	158
Table size	CxD	mm	200 x 190	200 x 190	200 x 220	200 x 220
T-slot width similar to DIN 650		mm	14	14	14	14
Ram bore Ø x Depth	E	mm	20 ^{H7} x 25	20 ^{H7} x 25	20 ^{H7} x 25	20 ^{H7} x 25
Ram area	F	mm	40 x 40	40 x 40	40 x 40	40 x 40
Port size			G 3/8"	G 3/8"	G 3/8"	G 3/8"
Air consumption/cm cyl. stroke		l	0,5	0,75	0,5	0,75
Space requirement	CxG	mm	200 x 385	200 x 385	200 x 560	200 x 560
Stand height	K	mm	580	580	630	630
Weight		kg	ca. 95	ca. 96	ca. 135	ca. 136

DA-range

DA presses are the logical implementation of modern press technology for direct-acting pneumatic presses. Due to their modular design, exactly the size needed for the application can be selected, thus optimising the price/performance ratio.

Standard stroke lengths from 40 mm to 120 mm are available in 20 mm steps. Special lengths can be provided on request.

Direct-acting pneumatic presses produce a constant force over the whole stroke length. All direct-acting pneumatic presses can be provided as automation components or with **mäder** controllers for individual workstations.

The processing of sheet metal, printed circuit boards and other bulky components requires presses to have a larger throat. XL-DA presses with 250 mm and 300 mm throat enable even these workpieces to be processed.

L-DA presses with up to 350 mm daylight are used for tall parts which require more vertical space. For dimensions which lie outside the standard, presses with press-frames in welded design can be manufactured to your specifications.

DA presses are practically maintenance-free, as all moving parts are mounted in bearings. Cylinders are pre-greased and are therefore suitable for oil-free operation.

Quality features:

- Anti-twist, hard-chrome-plated ram guided in Teflon bushes
- Simple adjustment of the height of the press head using a threaded spindle and right-angle gearbox
- Side-mounted measuring strip for fast reproduction of settings when changing the tool
- Practically maintenance-free double-acting cylinder
- Adjustable cylinder end-position damping
- Low noise: less than 75 dB

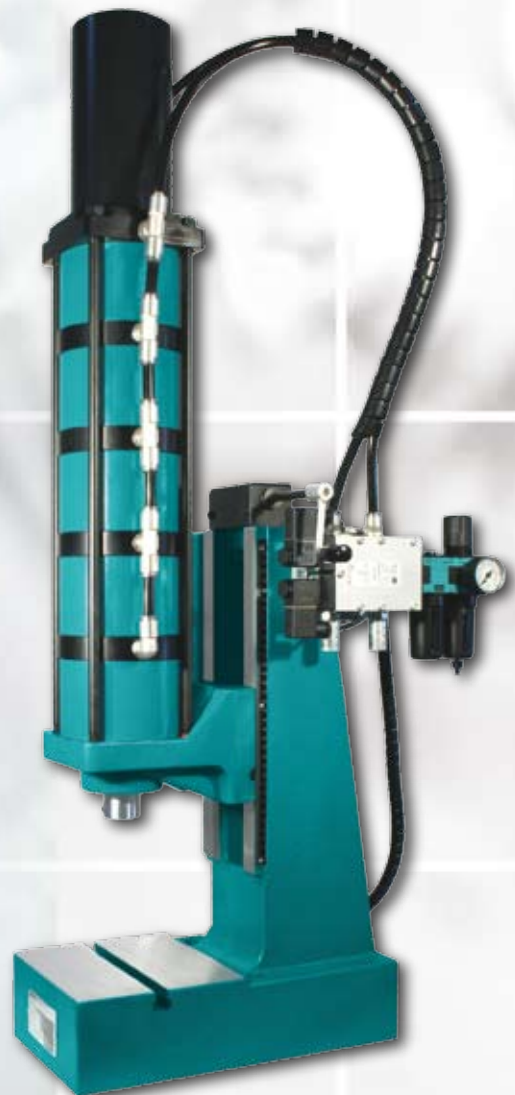

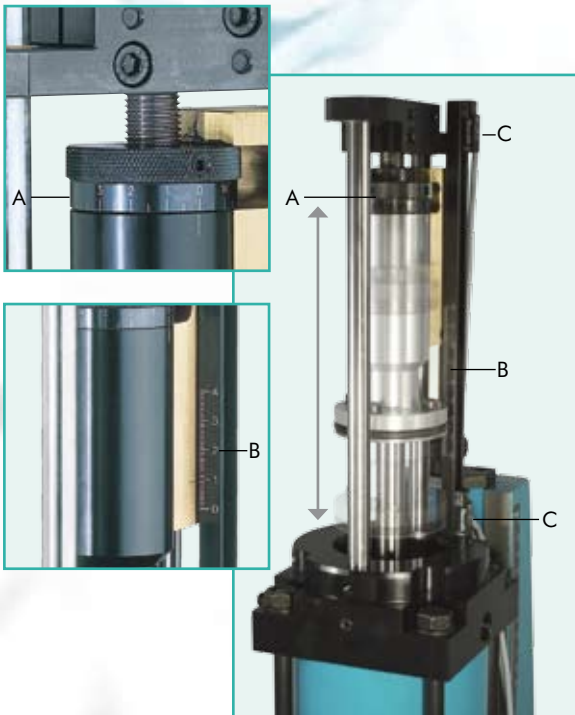

Sensors are not included

Adjusting the stroke of DA presses

DA presses are fitted as standard with an innovative, precise and easy-to-use system which enables accurate stroke adjustment and protects the ram against twisting.

Operation:

- The press depth can be adjusted to a reading accuracy of 0.05 mm over the whole stroke length with only one scale nut (A). The stroke length can be read off using the side scale (B) and the vernier on the scale nut (A).
- The position of the ram can be checked by means of reed contacts (C) which are slid onto the standard scale.
- The sensors do not have to be readjusted when the stroke length is changed, as the stroke length control magnets always move to the same end positions.

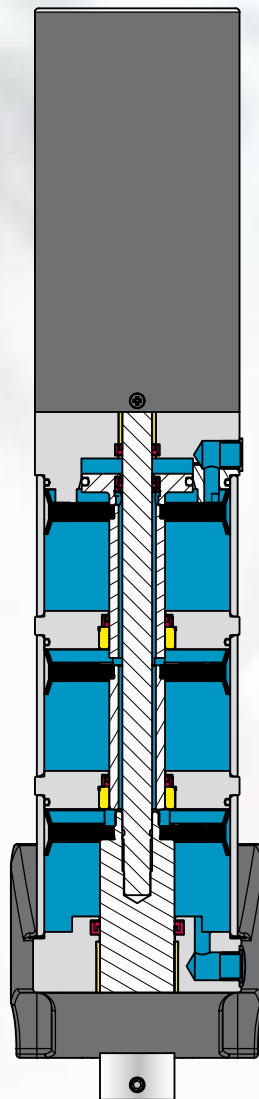

Tandem cylinders

The energy-efficient tandem cylinder design is used for larger forces. Several pneumatic cylinders are connected in tandem thus increasing the force of the cylinder accordingly. The air consumption is optimised, as the return stroke is only via one cylinder chamber. The press can be operated using only two air connections, as the air is channelled within the pneumatic cylinder.

The accessories

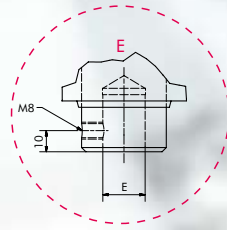
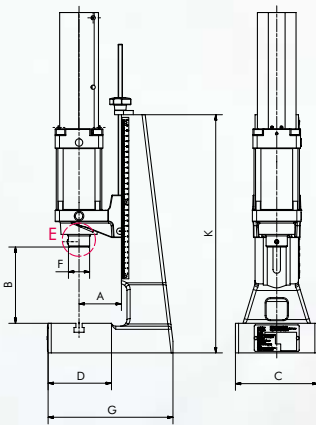
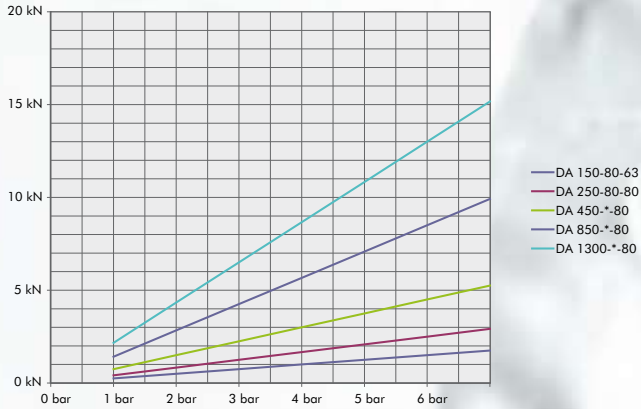
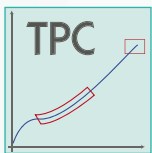
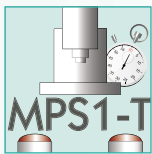
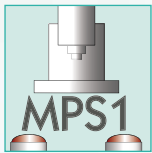
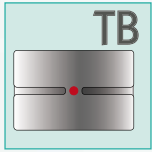

DA range with round ram
L-DA range with round ram, daylight with 350 mm

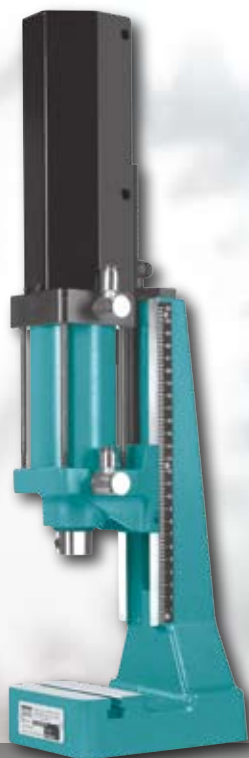

DA 150-80-63

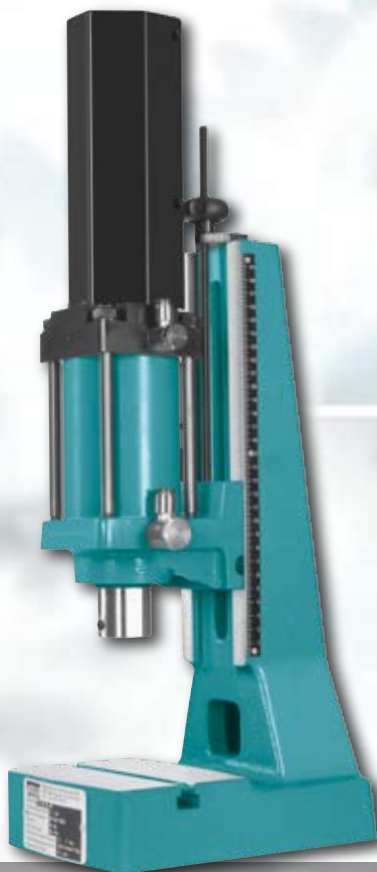

DA 250-80-80

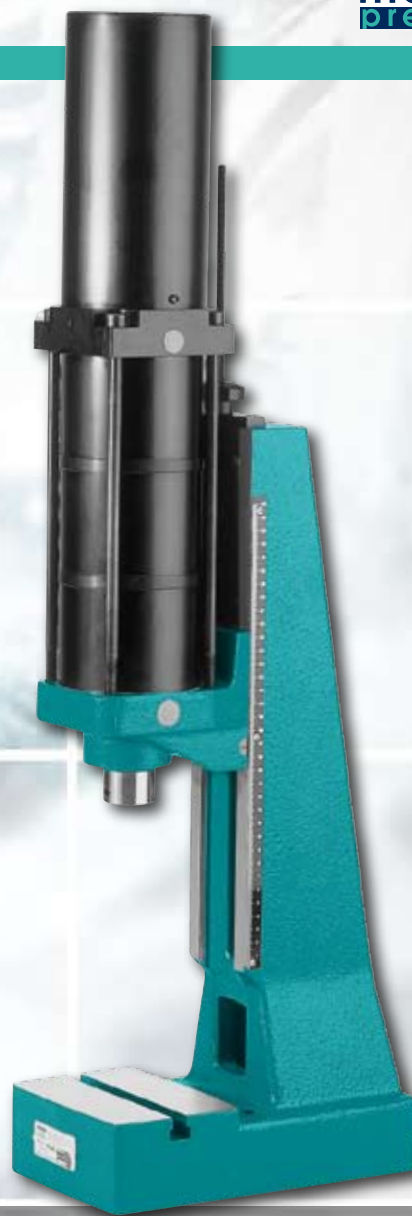

L-DA 1300-40-80

Type			DA 150-80-63	DA 250-80-80	L-DA 250-80-80	DA 450*-80	L-DA 450*-80	DA 850*-80	L-DA 850*-80	L-DA 1300*-80
Capacity		kN	1,5	2,5	2,5	4,5	4,5	8,5	8,5	13
Working stroke*		mm	80	80	80	40/60/80/ 100/120	40/60/80/ 100/120	40/60/80/ 100/120	40/60/80/ 100/120	40/60/80/ 100/120
Throat	A	mm	63	80	80	80	80	80	80	80
Daylight	B	mm	40 - 215	70 - 280	65 - 390	58 - 243	65 - 350	58 - 243	65 - 350	65 - 350
Table size	CxD	mm	100 x 65	157 x 115	157 x 115	157 x 115	157 x 115	157 x 115	157 x 115	157 x 115
T-slot width similar to DIN 650		mm	10	12	12	12	12	12	12	12
Ram bore Ø x Depth	E	mm	16 ^{H7} x 25	20 ^{H7} x 25	20 ^{H7} x 25	20 ^{H7} x 25	20 ^{H7} x 25	20 ^{H7} x 25	20 ^{H7} x 25	20 ^{H7} x 25
Ram Ø	F	mm	30	40	40	40	40	40	40	40
Port size			G 1/4"	G 1/4"	G 1/4"	G 3/8"	G 3/8"	G 3/8"	G 3/8"	G 3/8"
Air consumption/cm cyl. stroke		l	0,2	0,3	0,3	1,0	1,0	1,5	1,5	2,1
Space requirement	CxG	mm	110 x 164	157 x 237	155 x 280	155 x 237	155 x 280	155 x 237	155 x 280	155 x 280
Stand height	K	mm	355	450	570	450	570	450	570	570
Weight		kg	ca. 11,5	ca. 25	ca. 31	ca. 28	ca. 34	ca. 31	ca. 37	ca. 40

Accessories (see Page 7)	Please specify when ordering.								
Table bore 12 ^{H7}	TB	TB	TB	TB	TB	TB	TB	TB	TB

* Specify the stroke length when ordering.
Valve and service unit only included with controller. Design may vary.

The accessories

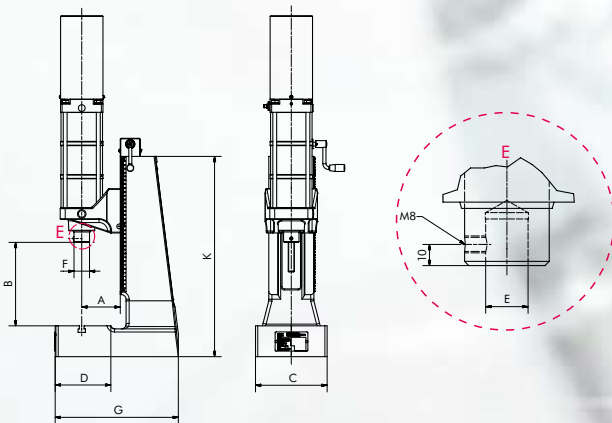
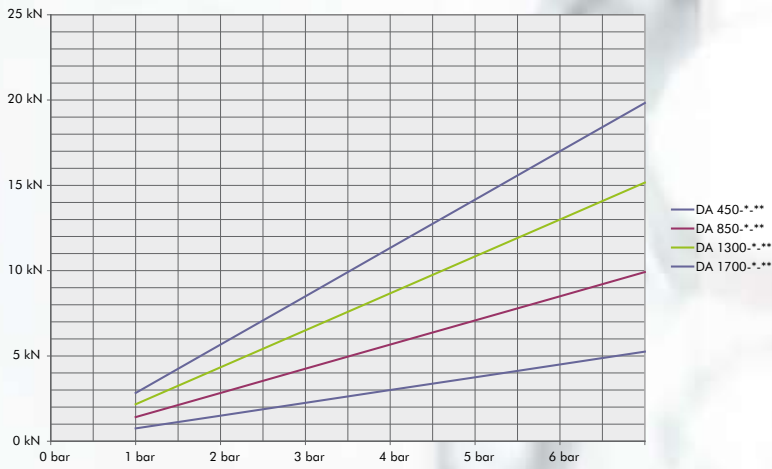
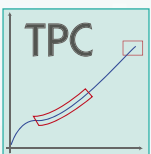
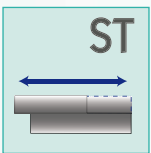
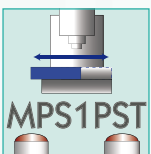
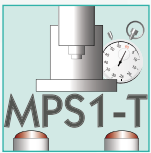
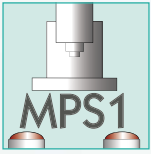



DA 850-40-100



DA 1300-40-130

Type			DA 450-*-100	DA 850-*-100	DA 1300-*-100	DA 1700-*-100	DA 450-*130	DA 850-*-130	DA 1300-*-130	DA 1700-*-130
Capacity		kN	4,5	8,5	13,0	17,0	4,5	8,5	13,0	17,0
Working stroke*		mm	40/60/80/ 100/120	40/60/80/ 100/120	40/60/80/ 100/120	40/60/80/ 100/120	40/60/80/ 100/120	40/60/80/ 100/120	40/60/80/ 100/120	40/60/80/ 100/120
Throat	A	mm	100	100	100	100	130	130	130	130
Daylight	B	mm	60 - 285	60 - 285	60 - 285	60 - 285	70 - 325	70 - 325	70 - 325	70 - 325
Table size	CxD	mm	185 x 145	185 x 145	185 x 145	185 x 145	200 x 190	200 x 190	200 x 190	200 x 190
T-slot width similar to DIN 650		mm	12	12	12	12	14	14	14	14
Ram bore Ø x Depth	E	mm	20 ^{H7} x 25	20 ^{H7} x 25	20 ^{H7} x 25	20 ^{H7} x 25	20 ^{H7} x 25	20 ^{H7} x 25	20 ^{H7} x 25	20 ^{H7} x 25
Ram Ø	F	mm	40	40	40	40	40	40	40	40
Port size			G 3/8"	G 3/8"	G 3/8"	G 3/8"	G 3/8"	G 3/8"	G 3/8"	G 3/8"
Air consumption/cm cyl. stroke		l	1,0	1,5	2,1	2,6	1,0	1,5	2,1	2,6
Space requirement	CxG	mm	185 x 320	185 x 320	185 x 320	185 x 320	200 x 385	200 x 385	200 x 385	200 x 385
Stand height	K	mm	520	520	520	520	580	580	580	580
Weight		kg	ca. 62	ca. 65	ca. 68	ca. 71	ca. 77	ca. 80	ca. 83	ca. 86

* Specify the stroke length when ordering.
Valve and service unit only included with controller. Design may vary.

The accessories

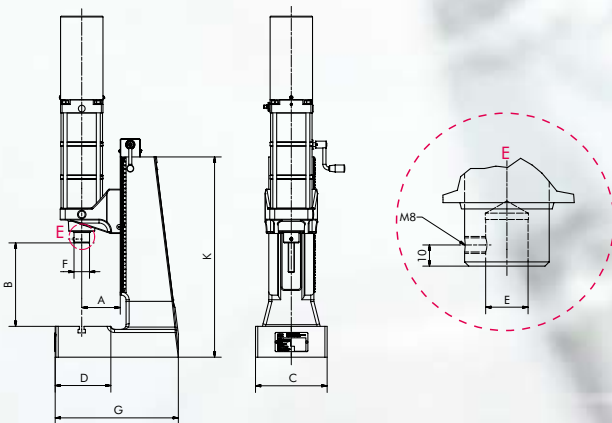
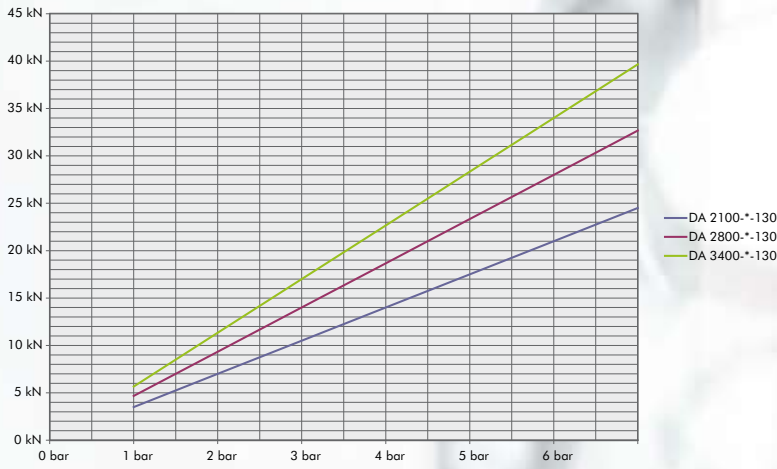
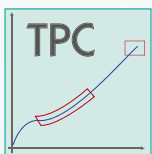
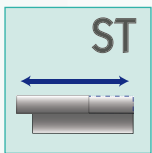
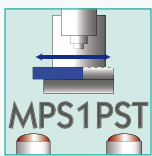
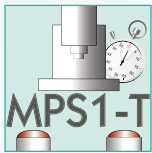
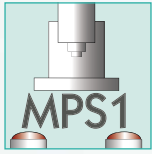



DA 3400-40-130

Type			DA 2100- [*] -130	DA 2800- [*] 130	DA 3400- [*] -130
Capacity		kN	21,0	28,0	34,0
Working stroke [*]		mm	40/60/80/100/120	40/60/80/100/120	40/60/80/100/120
Throat	A	mm	130	130	130
Daylight	B	mm	75 - 330	75 - 330	75 - 330
Table size	CxD	mm	200 x 190	200 x 190	200 x 190
T-slot width similar to DIN 650		mm	14	14	14
Ram bore Ø x Depth	E	mm	20 ^{H7} x 25	20 ^{H7} x 25	20 ^{H7} x 25
Ram Ø	F	mm	40	40	40
Port size			G 3/8"	G 3/8"	G 3/8"
Air consumption/cm cyl. stroke		l	3,0	3,7	4,5
Space requirement	CxG	mm	200 x 385	200 x 385	200 x 385
Stand height	K	mm	580	580	580
Weight		kg	ca. 92	ca. 99	ca. 105

^{*} Specify the stroke length when ordering.
Valve and service unit only included with controller. Design may vary.

Die accessories

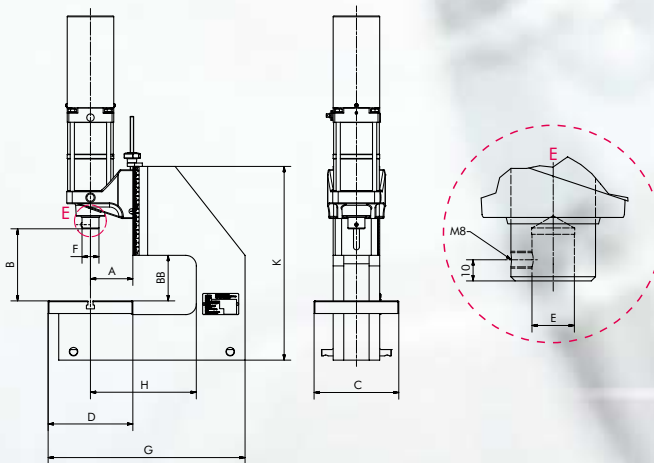
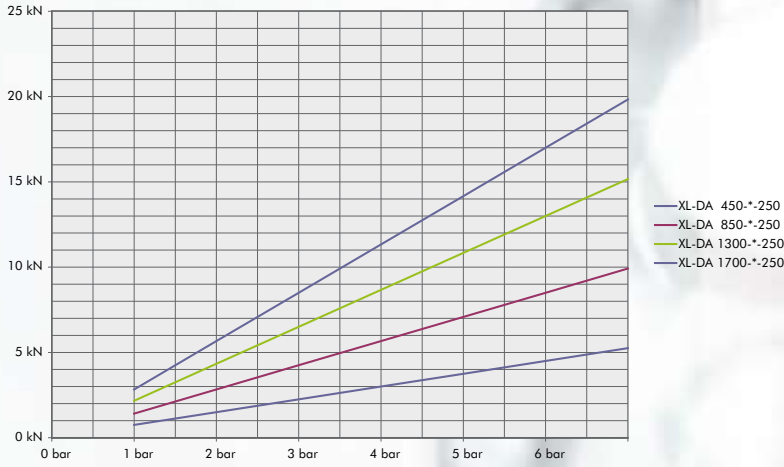
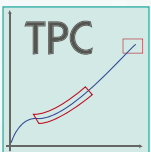
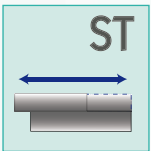
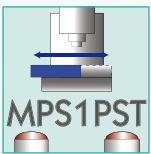
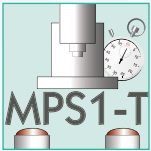
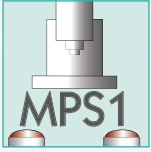

XL direct-acting pneumatic presses
DA range with round ram, with 250 mm throat



XL-DA 850-40

Type			XL-DA 450-*-250	XL-DA 850-*-250	XL-DA 1300-*-250	XL-DA 1700-*-250
Capacity		kN	4,5	8,5	13,0	17,0
Working stroke*		mm	40/60/80/100/120	40/60/80/100/120	40/60/80/100/120	40/60/80/100/120
Throat	A	mm	100	100	100	100
Throat C-frame	H	mm	250	250	250	250
Daylight	B	mm	75 - 175	75 - 175	75 - 175	75 - 175
Daylight C-frame	BB	mm	100	100	100	100
Table size	CxD	mm	200 x 200	200 x 200	200 x 200	200 x 200
T-slot width similar to DIN 650		mm	12	12	12	12
Ram bore Ø x Depth	E	mm	20 ^{H7} x 25	20 ^{H7} x 25	20 ^{H7} x 25	20 ^{H7} x 25
Ram Ø	F	mm	40	40	40	40
Port size			G 3/8"	G 3/8"	G 3/8"	G 3/8"
Air consumption/cm cyl. stroke		l	1,0	1,5	2,1	2,6
Space requirement	CxG	mm	200 x 465	200 x 465	200 x 465	200 x 465
Stand height	K	mm	465	465	465	465
Weight		kg	ca. 57	ca. 60	ca. 63	ca. 66

* Specify the stroke length when ordering.
Valve and service unit only included with controller. Design may vary.

The accessories

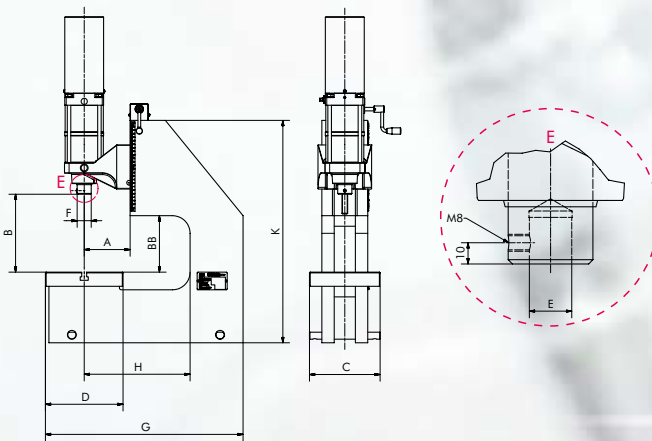
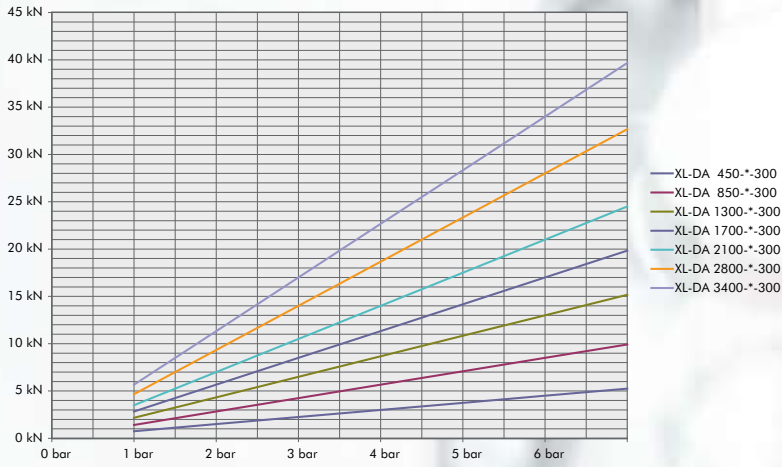
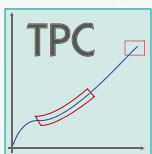
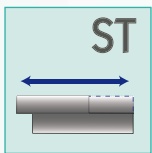
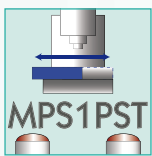
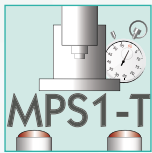
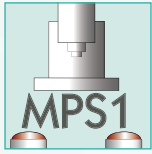

XL direct-acting pneumatic presses

DA range with round ram, with 300 mm throat



XL-DA 1300-40-300

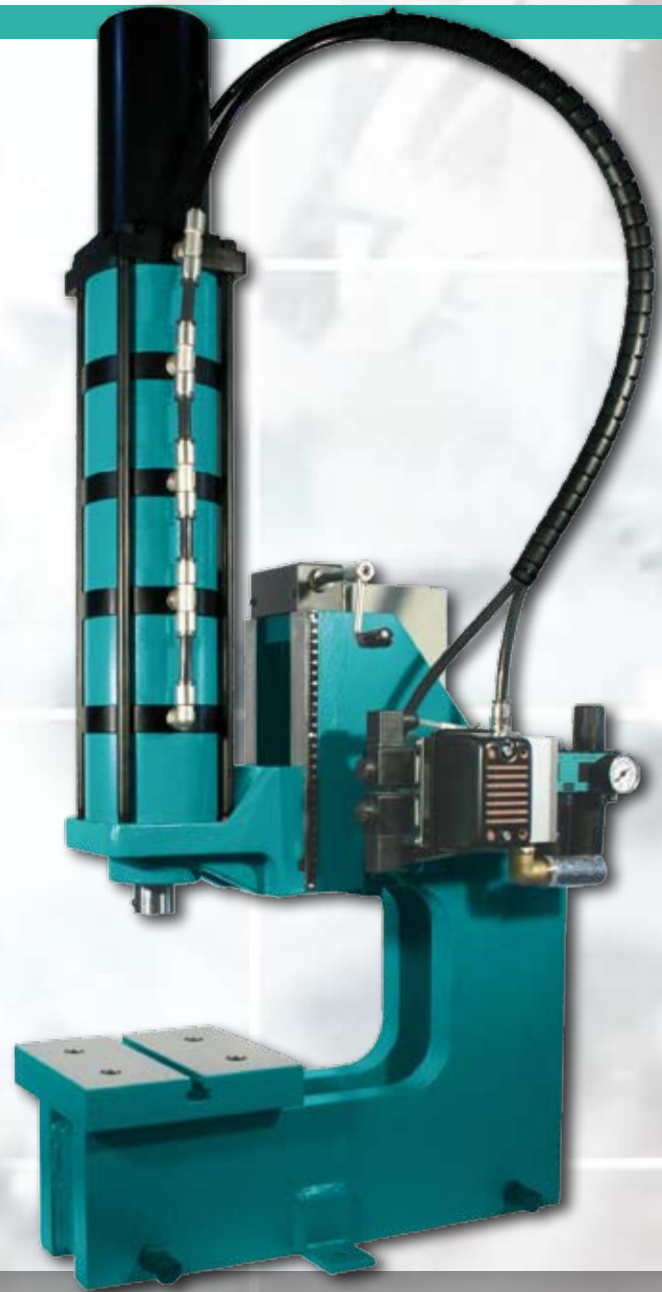

XL-DA 3400-40-300

Type			XL-DA 450*-300	XL-DA 850*-300	XL-DA 1300*-300	XL-DA 1700*-300	XL-DA 2100*-300	XL-DA 2800*-300	XL-DA 3400*-300
Capacity		kN	4,5	8,5	13,0	17,0	21,0	28,0	34,0
Working stroke*		mm	40/60/80/120	40/60/80/120	40/60/80/120	40/60/80/120	40/60/80/120	40/60/80/120	40/60/80/120
Throat	A	mm	130	130	130	130	130	130	130
Throat C-frame	H	mm	300	300	300	300	300	300	300
Daylight	B	mm	140 - 175	140 - 175	140 - 175	140 - 175	130 - 275	130 - 275	130 - 275
Daylight C-frame	BB	mm	158	158	158	158	158	158	158
Table size	CxD	mm	200 x 220	200 x 220	200 x 220	200 x 220	200 x 220	200 x 220	200 x 220
T-slot width similar to DIN 650		mm	14	14	14	14	14	14	14
Ram bore Ø x Depth	E	mm	20 ^{H7} x 25	20 ^{H7} x 25	20 ^{H7} x 25	20 ^{H7} x 25	20 ^{H7} x 25	20 ^{H7} x 25	20 ^{H7} x 25
Ram Ø	F	mm	40	40	40	40	40	40	40
Port size			G 3/8"	G 3/8"	G 3/8"	G 3/8"	G 3/8"	G 3/8"	G 3/8"
Air consumption/cm cyl. stroke		l	1,0	1,5	2,1	2,6	3,0	3,7	4,5
Space requirement	CxG	mm	200 x 560	200 x 560	200 x 560	200 x 560	200 x 560	200 x 560	200 x 560
Stand height	K	mm	630	630	630	630	630	630	630
Weight		kg	ca. 135	ca. 138	ca. 141	ca. 144	ca. 141	ca. 158	ca. 164

* Specify the stroke length when ordering.

Valve and service unit only included with controller. Design may vary.

The accessories

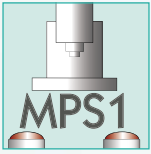

DAF direct-acting press cylinders with flange have been designed for flexible use in special machines. DAF press cylinders come with all the advantages of modern pneumatic presses as standard:

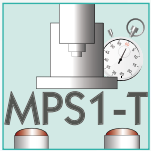

- Stepless adjustment of stroke length
- Adjustable end-position damping
- Tool mounting hole
- Easy to automate

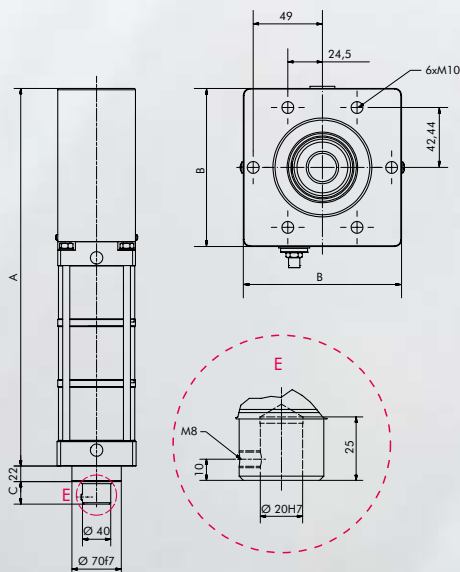
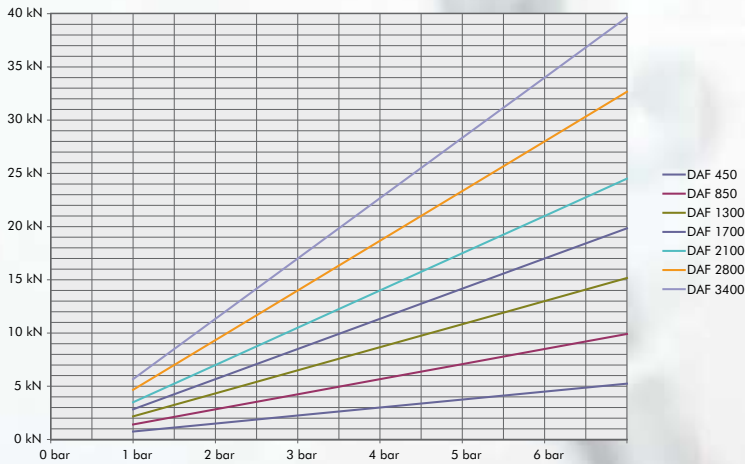
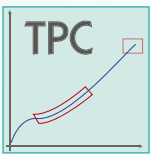



DAF cylinders

Type	Capacity kN at 6 bar	Return force kN at 6 bar	stroke mm	A mm	B mm	C mm
DAF 450-40	4,5	4	0 - 40	363	112	32
DAF 450-60	4,5	4	0 - 60	403	112	32
DAF 450-80	4,5	4	0 - 80	443	112	32
DAF 450-100	4,5	4	0 - 100	483	112	32
DAF 450-120	4,5	4	0 - 120	523	112	32
DAF 850-40	8,5	4	0 - 40	449	112	32
DAF 850-60	8,5	4	0 - 60	509	112	32
DAF 850-80	8,5	4	0 - 80	569	112	32
DAF 850-100	8,5	4	0 - 100	629	112	32
DAF 850-120	8,5	4	0 - 120	689	112	32
DAF 1300-40	13	4	0 - 40	535	112	32
DAF 1300-60	13	4	0 - 60	615	112	32
DAF 1300-80	13	4	0 - 80	695	112	32
DAF 1300-100	13	4	0 - 100	775	112	32
DAF 1300-120	13	4	0 - 120	855	112	32
DAF 1700-40	17	4	0 - 40	621	112	32
DAF 1700-60	17	4	0 - 60	721	112	32
DAF 1700-80	17	4	0 - 80	821	112	32
DAF 1700-100	17	4	0 - 100	921	112	32
DAF 1700-120	17	4	0 - 120	1021	112	32
DAF 2100-40	21	19	0 - 40	581	134	38
DAF 2100-60	21	19	0 - 60	661	134	38
DAF 2100-80	21	19	0 - 80	741	134	38
DAF 2100-100	21	19	0 - 100	821	134	38
DAF 2100-120	21	19	0 - 120	901	134	38
DAF 2800-40	28	26	0 - 40	689	134	38
DAF 2800-60	28	26	0 - 60	789	134	38
DAF 2800-80	28	26	0 - 80	889	134	38
DAF 2800-100	28	26	0 - 100	989	134	38
DAF 2800-120	28	26	0 - 120	1089	134	38
DAF 3400-40	34	32	0 - 40	797	134	38
DAF 3400-60	34	32	0 - 60	917	134	38
DAF 3400-80	34	32	0 - 80	1037	134	38
DAF 3400-100	34	32	0 - 100	1157	134	38
DAF 3400-120	34	32	0 - 120	1277	134	38

The accessories

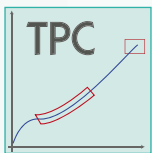
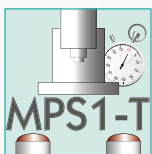
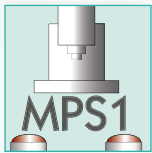
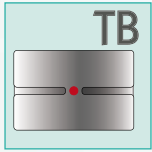

MicroPress® is a pneumatic press for smaller capacities with a robust press base. MicroPress® types are ideal for joining and shaping applications where components require low pressure and precise stroke depth. Examples are applications in medical engineering, electronics manufacturing and precision mechanics.

Quality features:

- Square ram
- Precision ram guide
- Adjustable stroke length
- Height-adjustable press head
- Practically maintenance-free cylinder
- Low noise

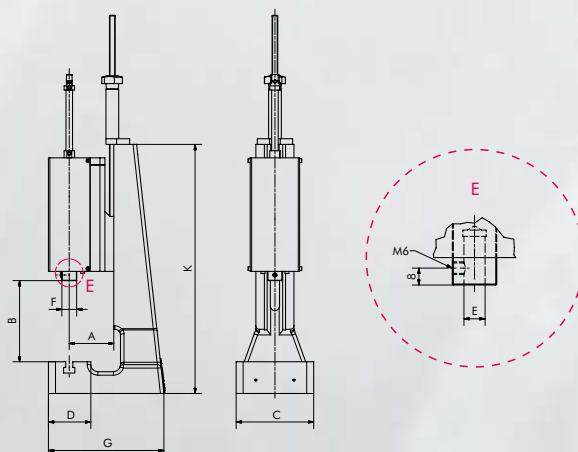
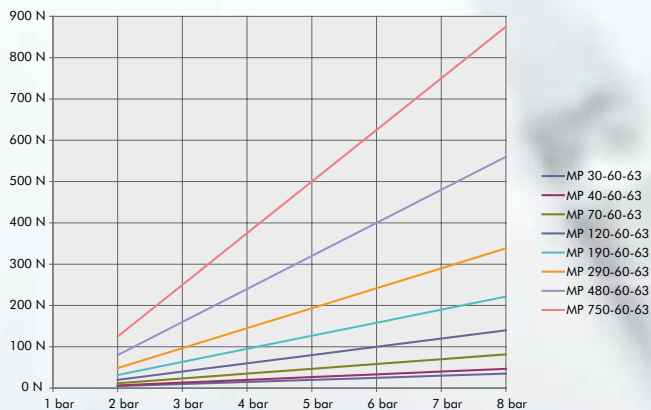
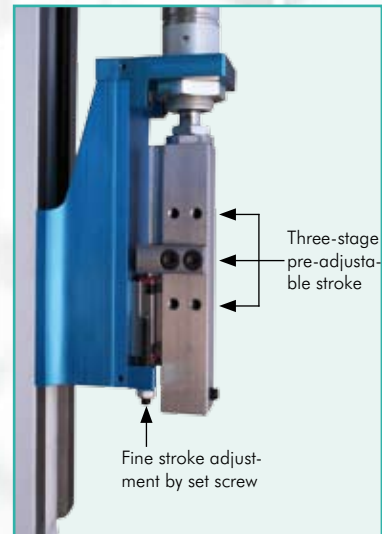



MicroPress 190-60-63

Type MicroPress			30-60-63	40-60-63	70-60-63	120-60-63	190-60-63	290-60-63	480-60-63	750-60-63
Capacity	N		30	40	70	120	190	290	480	750
Working stroke	mm		5-60	5-60	5-60	5-60	5-60	5-60	5-60	5-60
Throat	A	mm	63	63	63	63	63	63	63	63
Daylight	B	mm	43 - 208	43 - 208	43 - 208	43 - 208	43 - 208	43 - 208	43 - 208	43 - 208
Table size	CxD	mm	100 x 65	100 x 65	100 x 65	100 x 65	100 x 65	100 x 65	100 x 65	100 x 65
T-slot width similar to DIN 650		mm	10	10	10	10	10	10	10	10
Ram bore Ø x Depth	E	mm	10 ^{H7} x 25	10 ^{H7} x 25	10 ^{H7} x 25	10 ^{H7} x 25	10 ^{H7} x 25	10 ^{H7} x 25	10 ^{H7} x 25	10 ^{H7} x 25
Ram area	F	mm	21 x 21	21 x 21	21 x 21	21 x 21	21 x 21	21 x 21	21 x 21	21 x 21
Port size			M5	M5	M5	M5	G ₈ ¹ ''	G ₈ ¹ ''	G ₈ ¹ ''	G ₄ ¹ ''
Air consumption/60mm stroke	l		0,04	0,06	0,08	0,16	0,24	0,38	0,64	1,0
Space requirement	CxG	mm	110 x 164	110 x 164	110 x 164	110 x 164	110 x 164	110 x 164	110 x 164	110 x 164
Stand height	K	mm	355	355	355	355	355	355	355	355
Weight	kg		ca. 9,5	ca. 10	ca. 10	ca. 11	ca. 11	ca. 12	ca. 12	ca. 12

Accessories (see Page 7)	Please specify when ordering.									
Table bore 12 ^{H7}	TB	TB	TB	TB	TB	TB	TB	TB	TB	TB

MicroPress®

mäder hydropneumatic presses are initially driven by compressed air only and activate the hydraulic power stroke automatically. They combine the advantages of pneumatic and hydraulic presses. In the pneumatically driven fast stroke, the workpiece is approached rapidly with low force. The hydraulic power stroke is then activated automatically when resistance is encountered.

Because of this, the applied energy is used to the most economic effect particularly in these models. The operation of hydropneumatic presses is described on the following page. As **mäder** hydropneumatic presses do not need a hydraulic power pack, they can also be used where space is at a premium. All hydropneumatic presses can be provided with the standard **mäder** controller or with customer-specified controllers.

The processing of sheet metal, printed circuit boards and other bulky components requires presses to have a larger throat. XL-HP presses with 300 mm throat enable even these parts to be processed. For dimensions which lie outside the standard, presses with stands in welded design can be manufactured to your specifications.

Quality features:

- Anti-twist, hardened ram
- Long, honed ram guide for maximum precision
- Two power stroke lengths provided as standard
- Simple adjustment of the height of the press head using a threaded spindle and right-angle gearbox
- Side-mounted measuring strip for fast reproduction of settings when changing the tool
- Low noise: less than 75 dB

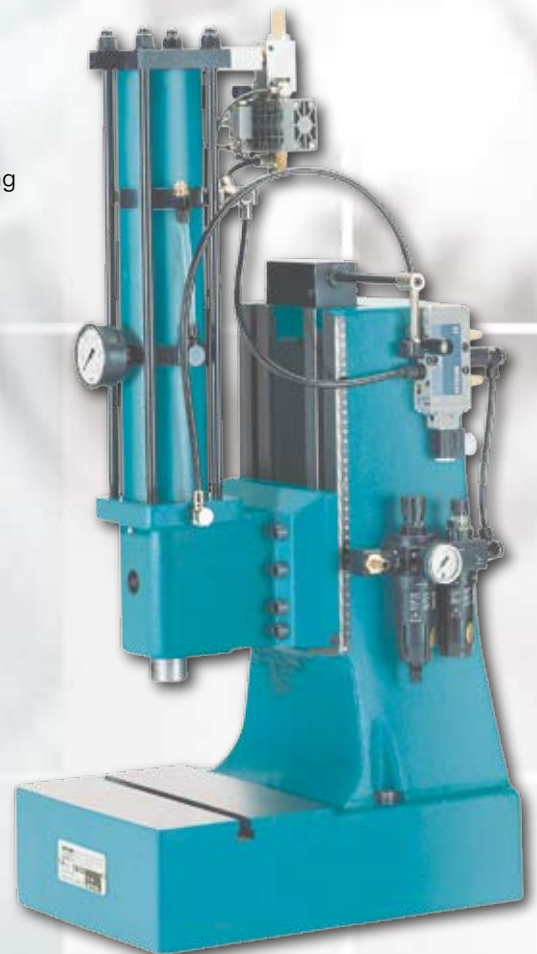

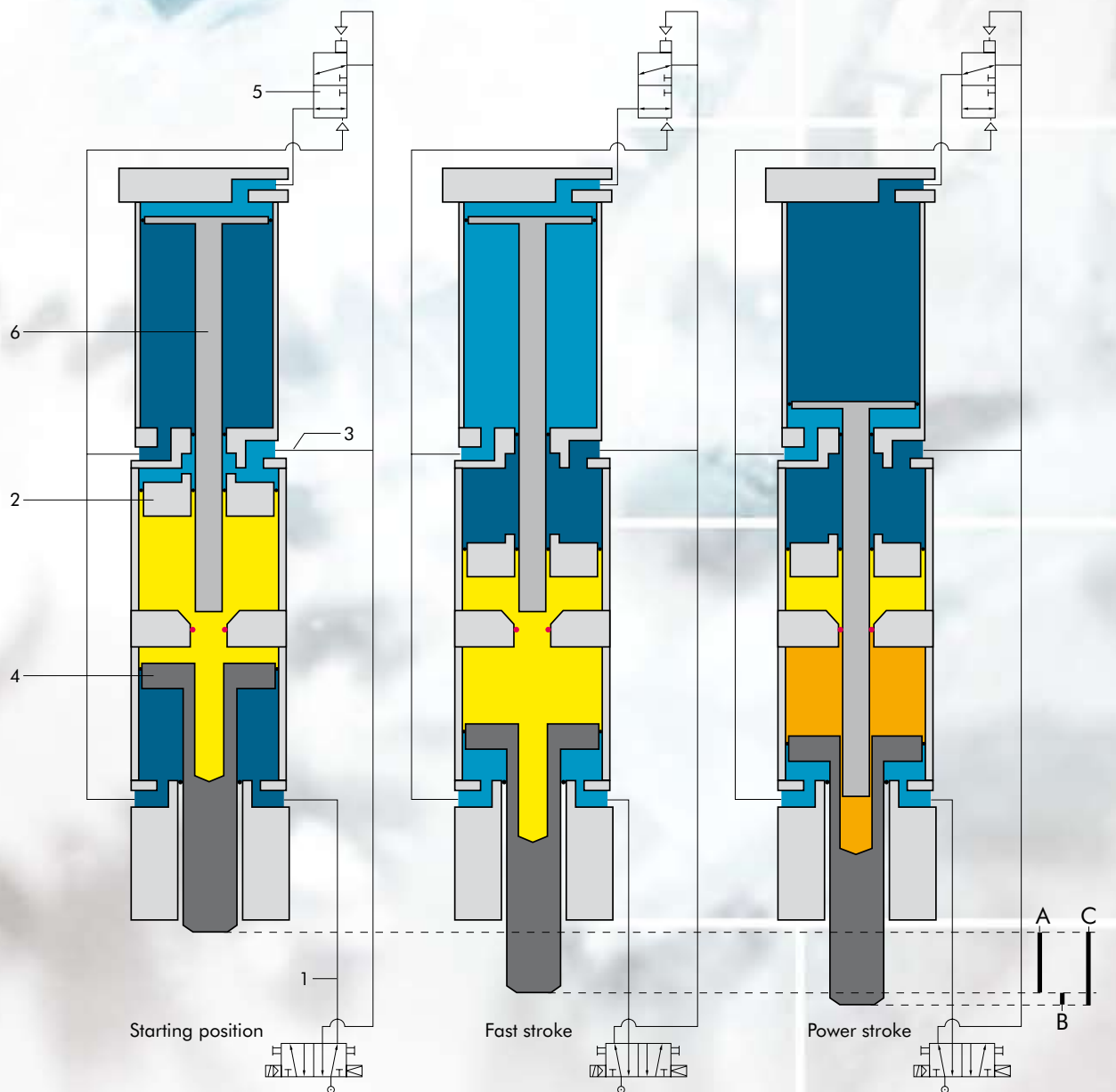

Description of operation:

Starting position:

Compressed air is applied to the compressed air line (1); the rest of the system is unpressurised.

Fast stroke (A):

Pressure is applied to the fast stroke piston (2) via the compressed air connection (3). The piston moves out and pushes the power stroke piston (4) down by means of the oil at high speed onto the workpiece.

- Oil without pressure
- Oil under pressure
- Air without pressure
- Air under pressure

- A = Fast stroke
- B = Power stroke
- C = Total stroke

Power stroke (B):

The changeover unit (5) now switches over automatically; the plunger (6) is pressurised with compressed air, moves out and closes the oil chamber causing the power transmission to take place. The ram (4) moves out at reduced speed and with increased force in the power stroke.

Return stroke (C):

System reversal; all pistons return simultaneously with pneumatic force.

The accessories

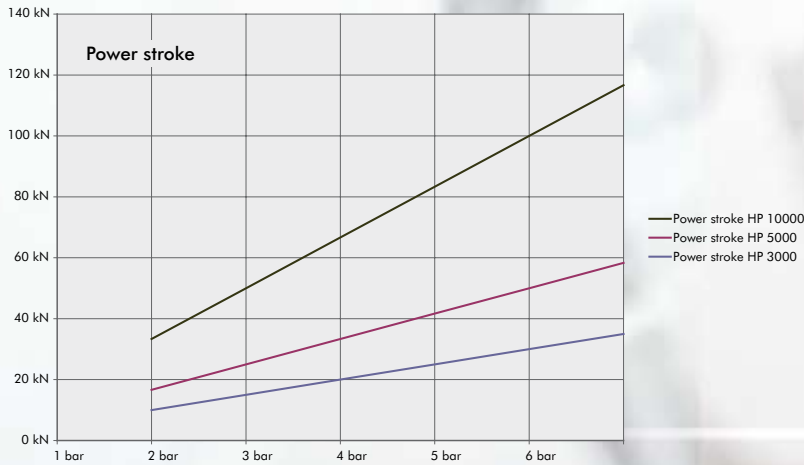
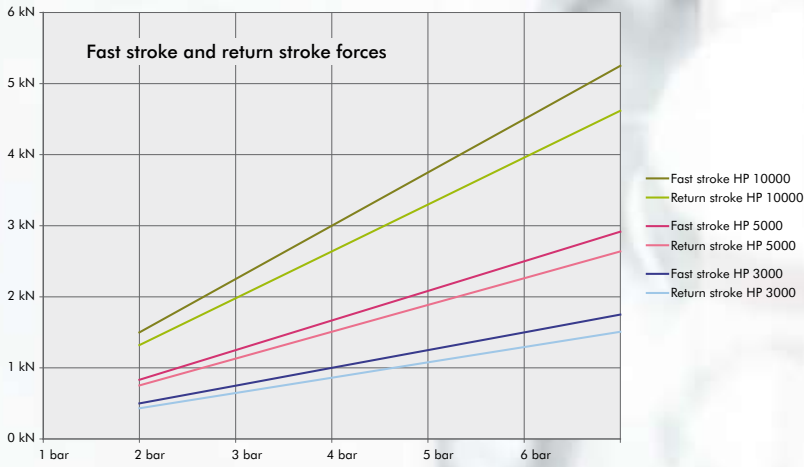
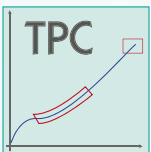
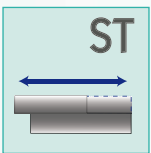
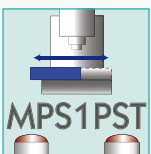
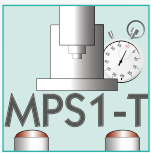
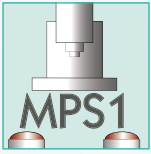

HP-Range

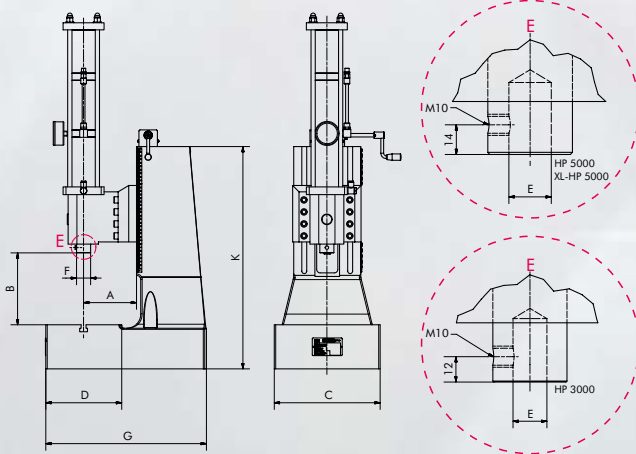

XL-HP-Range

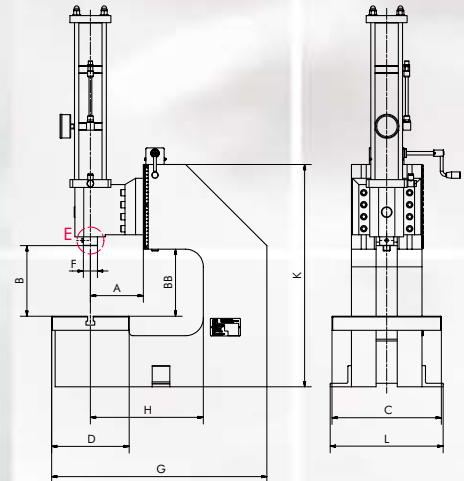

HP range
XL-HP range with 300 mm throat

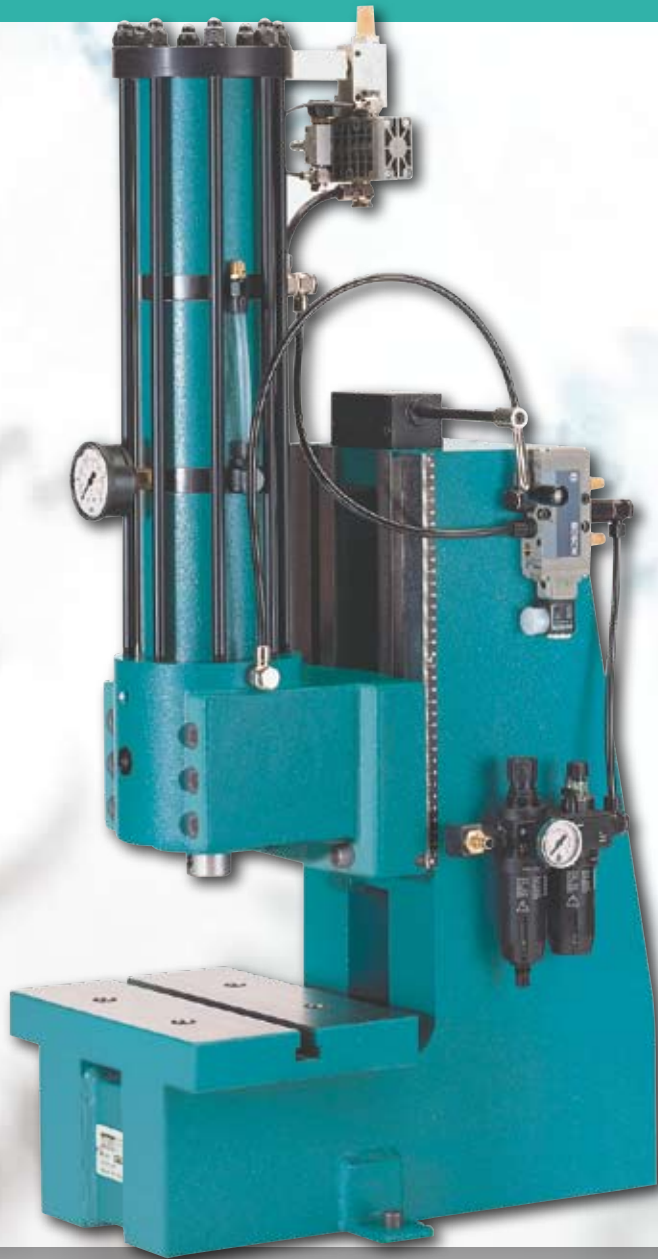

HP 10000 HV

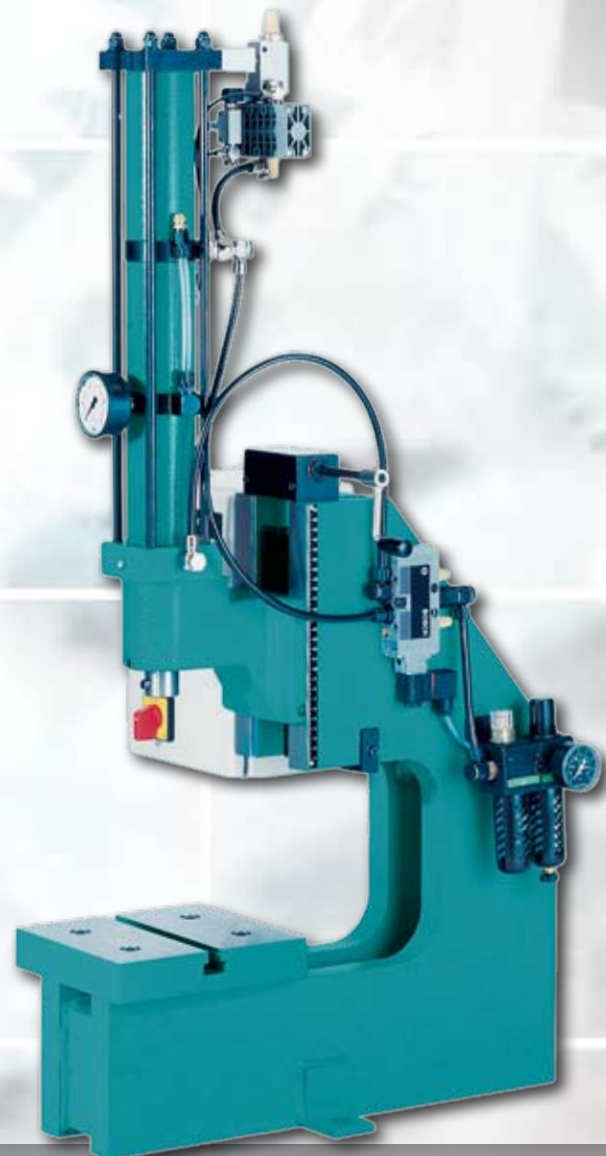

XL-HP 3000 HV

Type		HP 3.000 HV	HP 5.000 HV	HP 10.000 HV	XL-HP 3.000 HV	XL-HP 5.000 HV	XL-HP 10.000 HV
Capacity	kN	30	50	100	30	50	100
Power stroke	mm	40	50	50	40	50	50
thereof power stroke*	mm	4/8	5/10	5/10	4/8	5/10	5/10
Capacity of rapid stroke 6 bar	kN	1,5	2,5	4,5	1,5	2,5	4,5
Capacity of return stroke bei 6 bar	kN	1,3	1,7	4,1	1,3	1,7	4,1
Throat	A mm	130	150	150	130	150	150
Throat C-frame	H mm	-	-	-	300	300	300
Daylight	B mm	123 - 322	119 - 320	117 - 312	189 - 327	145 - 235	145 - 235
Daylight C-frame	BB mm	-	-	-	158	190	190
Table size	CxD mm	200 x 190	300 x 210	310 x 220	200 x 220	310 x 220	310 x 220
T-slot width similar to DIN 650	mm	14	14	14	14	16	16
Ram bore Ø x Depth	E mm	16 ^{H7} x 30	20 ^{H7} x 34	20 ^{H7} x 34	16 ^{H7} x 30	20 ^{H7} x 34	20 ^{H7} x 34
Ram Ø	F mm	35	40	40	35	40	40
Port size		G 1/4"	G 1/4"	G 1/4"	G 1/4"	G 1/4"	G 1/4"
Space requirement	LxG mm	200 x 385	300x455	310 x 500	200 x 560	320 x 610	320 x 610
Stand height	K mm	580	630	650	630	630	630
Weight	kg	ca. 78	ca. 163	ca. 287	ca. 184	ca. 241	ca. 311

* Please specify when ordering.
Valve and service unit only included with controller. Design may vary.

mäder pneumatic and manual side tables simplify manual and automatic insertion and therefore increase the economic efficiency of assembly processes.

The Advantages:

- Insertion is carried out outside the danger area
- Parts can be preassembled spatially unhindered by the press
- Versatile options for automation and feed tasks
- Precise positioning of workpieces

Other quality features:

- Slide guide can be adjusted without play
- Precision cross-roller guide with high loading capacity
- Damping at both end positions
- mäder slide tables can be installed transversely or longitudinally
- Easy to automate
- Self-latching in end position

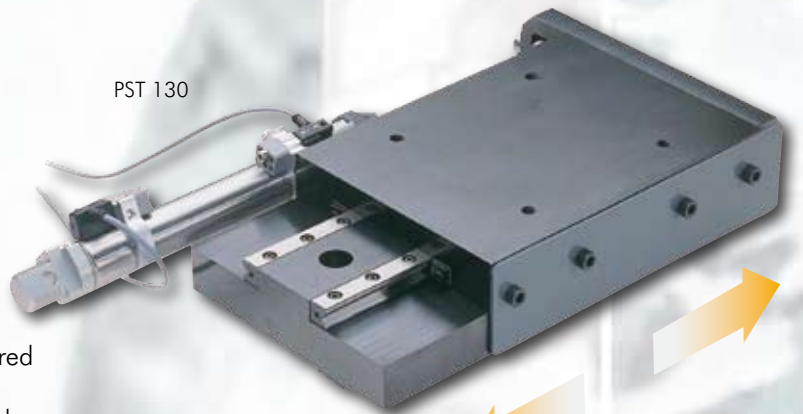

Typical application
PST 130 retracted

PST 130 extended

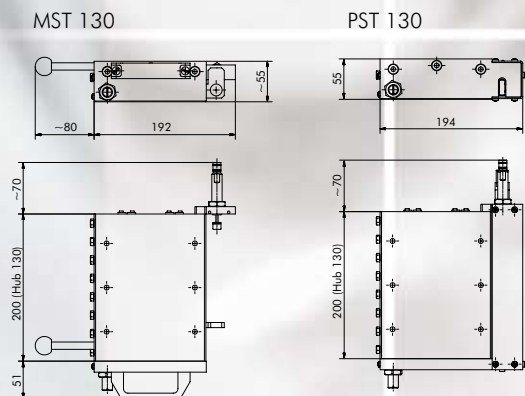

Type		MST 130	PST 130	Suitable for
stroke	mm	130	130	All mäder presses from 100 mm throat
Load capacity	kN	50	50	

Type MPS-1 controllers are type-tested and approved in accordance with the EC Machinery Directive 2006/42/EC to work with presses in workstations with manual loading and open tools. Here, safety is provided by the controller, which is designed to be both electrically and pneumatically redundant.

Type MPS-1 controllers comprise an electrical safety module with two hand buttons and an electronic 5-digit parts counter. It is possible to switch from two-hand mode to an external start signal for the press, e.g. a foot switch, by means of a key-operated switch if a safe tool is used. The foot switch or equivalent is not included with the Type MPS-1 controller.

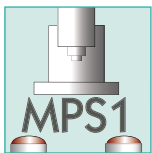

MPS-1
Basic version for two-hand operation.

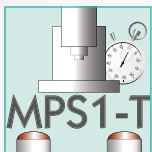

MPS-1 T
MPS-1 controller with additional stop time function. When the press has reached its end position, a timer can be used to determine when the return stroke should take place.

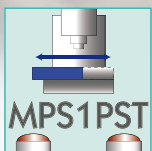

MPS-1 PST
This type of MPS-1 controller is used to control a pneumatic slide table in addition to the press. The scope of supply also includes the stop time function (see MPS-1 T)

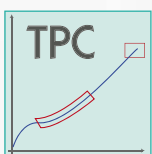

MPS-1 TPC
MPS-1 controller with an additional module TPC-MIDI for force/displacement monitoring.



Applications:

Joining and assembly processes using presses must today be carried out safely and if possible without retrospective checking. Specified parameters which define the press process must be maintained during production. Only in this way can the quality and safety of the manufactured product be guaranteed. For this reason, TPC-MIDI is used wherever consistent joining processes are required, the progress of which has to be checked and if applicable documented by means of software.

TPC-MIDI monitors the press operation, compares the actual progress with the requirements and subsequently evaluates it. In this way, reject parts can be reliably detected and separated out.

TPC-MIDI can be used both with hand-operated presses and with pneumatic presses. In the case of pneumatic presses, the **MPS-1 TPC** controller is supplied together with a PLC onto which the type-tested two-hand MPS-1 safety controller is superimposed.

However, the TPC-MIDI is also available as a pure system component if a PLC environment already exists, e.g. in an automation system.

The Advantages:

- TPC-MIDI can be programmed via the membrane keyboard or conveniently using the PC software.
- TPC-MIDI stores 8 different measuring programs
- 3 windows possible per program
- Modern curve evaluation via freely parameterisable windows
- 4 window types: Insertion, pass-through and block windows as well as an envelope curve.
- Force measurement directly in the force characteristic with DMS sensor developed especially for presses.
- Software for programming and saving measuring programs
- Documentation of each press operation



Laptop not included

DA 850-40-100 with MPS-1 TPC

Monitoring window

The following monitoring windows can be created with TPC-MIDI:

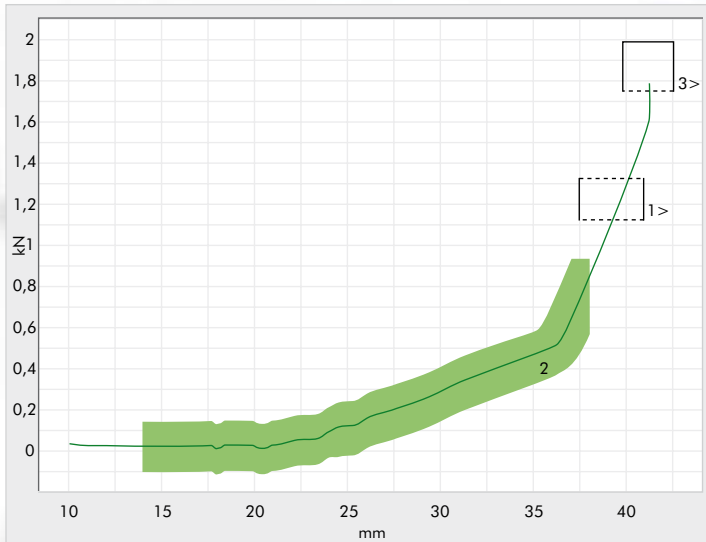

Pass-through window (1)

The force/displacement curve must pass through the window from the entry to the exit side as defined without one of the other window boundaries being infringed. The entry and exit sides can be freely selected.

Envelope curve (2)

The measuring curve must pass continuously through the envelope curve and must not infringe it. The envelope curve is taught by means of a teach-in process. Its X-axis parameters and the delta-Y, i.e. the force tolerance range, are defined subsequently.

Block window (3)

The block window monitors the final values of the press operation. With this type of window, the force/displacement curve must enter the specified entry side and must not leave the window again.

Programmable trigger points can be defined if the part geometry demands it. By programming the trigger point, the X-axis positions of the evaluation window are matched to the press operation and then refer to the trigger zero point.

We would be pleased to provide you with further information on the TPC-MIDI process monitor.

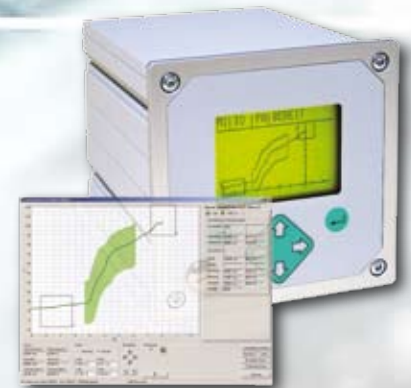

TPC-MIDI evaluation unit with software screenshot



Manual workstation with TPC-MIDI installed on an EP 500-40 toggle press

The Press & Tool Concept was developed in Switzerland by a renowned press manufacturer, and was taken over and perpetuated by **mäder** presses in 2008. It now represents Swiss technology made in Germany.

The Press & Tool Concept represents a well-rounded press and tool program for efficient manufacturing, particularly in the sheet metal processing industry, in force ranges from 10 kN - 35 kN.

Quality features:

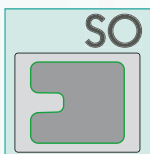

SOLID FRAME

Solid cast frames in C-design with high stability and low resilience for punching operations enable cost-effective free-cutting tools to be used in many working processes.

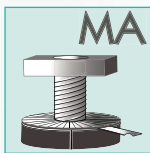

MICRO ADJUST

The precision height adjustment of the press table simplifies the set-up of Press & Tool Concept presses and increases their application possibilities. The standard scale disc enables a reading accuracy of 0.1 mm.

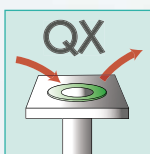

QUICK TOOL CHANGE

The standardised tool fixing system enables the different tools of the Press & Tool Concept to be changed in next to no time.

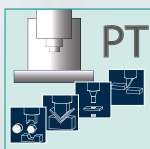

TOOL SYSTEM

Basic tool system for standard sheet metal processing applications such as punching, 90° bending, radial punching etc.

The components of the Press & Tool Concept

Hand-operated
toggle presses



KP 2.1 N

KP 2.1 W

KP 2.1 N Vario

KP 2.1 W Vario

Pneumatic toggle presses



KP 3.1 N

KP 3.1 W

Tool system W 14

Punching tool	Notching tool	Strip cutting tool	Radial punch
Angle-profile punch	Combination corner punch	Profile-rail tool	Profile cutting tool

2007 Presses / Tools

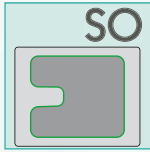

The standard toggle press of the Press & Tool Concept

Ideal for punching, bending, assembly, embossing, pressing, riveting, straightening, gluing.

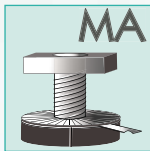

- Simple handling
- Factory-set end position with high repeat accuracy
- The MICRO ADJUST system enables the press table to be quickly and accurately adjusted in height
- Reading accuracy 0.1 mm
- Fixing by means of quick-clamp lever without additional tools
- Ideal in conjunction with the W 14 tool system
- Adapter piece included

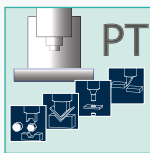
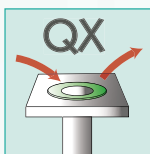

Fitted stripper frame (special accessory)

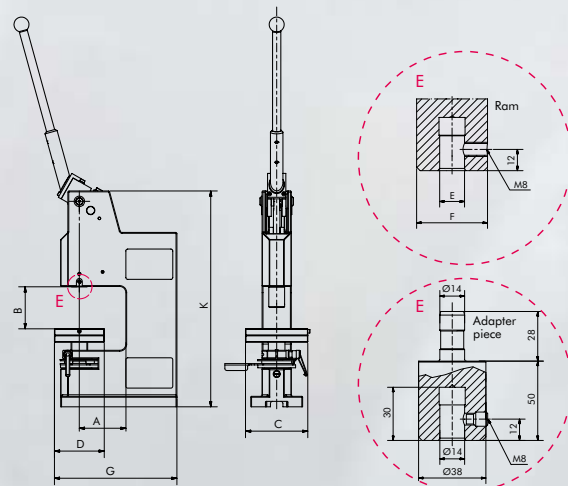
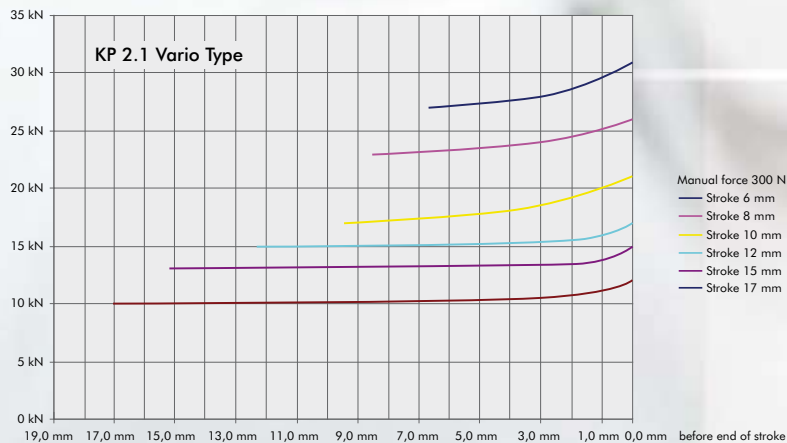



KP 2.1 N



KP 2.1 W Vario

Type			KP 2.1 N	KP 2.1 W	KP 2.1 N Vario	KP 2.1 W Vario
Capacity		kN	25	25	10 - 30	10 - 30
Working stroke	C	mm	27	27	6 - 17	6 - 17
Throat	A	mm	112	275	112	275
Daylight max.	B	mm	122	122	112	117
Table traverse		mm	70	70	70	70
Table size	D x H	mm	120 x 150	120 x 150	120 x 150	120 x 150
Ram bore Ø x Depth		mm	14 ^{H7} x 30	14 ^{H7} x 30	14 ^{H7} x 30	14 ^{H7} x 30
Ram Ø		mm	40 ^{h7}	40 ^{h7}	40 ^{h7}	40 ^{h7}
Space requirement	D x E	mm	125 x 280	125 x 520	125 x 280	125 x 520
Stand height	K	mm	520	520	520	520
Weight		ca. kg	35	85	35	85

The accessories

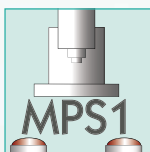
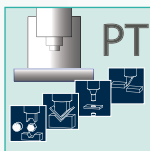
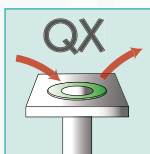
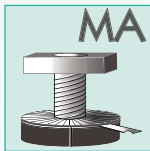
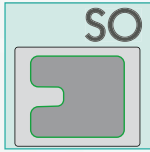

The pneumatic toggle presses of the KP 3.1 range

- Driven by double-acting pneumatic cylinders
- Factory-set end position with high repeat accuracy
- Anti-twist ram
- Adapter piece for bridging working height as standard
- The stroke limit allows the user to set up a low stroke length for safe working
- The MICRO ADJUST system enables the press table to be quickly and accurately adjusted in height
- Reading accuracy 0.1 mm
- Anti-twist
- Ideal in conjunction with the W 14 tool system
- Adapter included

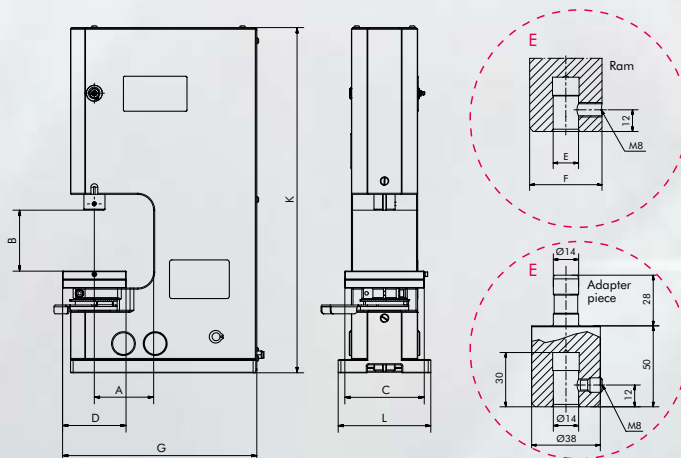
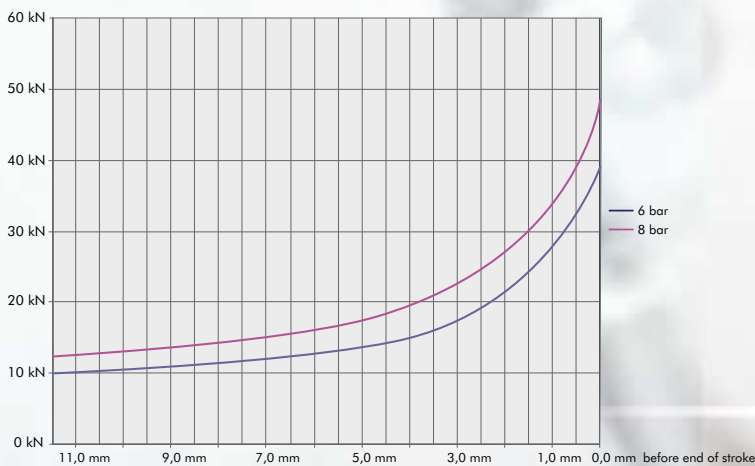

KP 3.1 N
 KP 3.1 W with 275 mm throat



KP 3.1 N



KP 3.1 W

Type			KP 3.1 N	KP 3.1 W
Capacity		kN	35	35
Working stroke		mm	6 - 27	6 - 27
Throat	A	mm	112	275
Daylight	B	mm	55 - 145	55 - 145
Table size	CxD	mm	120 x 150	120 x 150
Ram bore Ø x Depth	E	mm	14 ^{H7} x 30	14 ^{H7} x 30
Ram Ø	F	mm	40 ^{H7}	40 ^{H7}
Space requirement	CxG	mm	175 x 350	175 x 565
Stand height	K	mm	650	720
Weight		kg	75	125

Valve and service unit only included with controller. Design may vary.

Calculating the shear forces

The force required for punching is calculated from the following quantities:

- τ_{aBmax} = Shear strength of the material in N/mm^2
- l = Length of cut edge in mm
- s = Material thickness in mm

When the cutting edges of the stamp and die are parallel, the required shear force is calculated as follows:

$$F = \tau_{aBmax} \cdot l \cdot s$$

Calculation example:

Punching a hole \varnothing : 8,5 mm in 1,5 mm thick
AlMg 5 half-hard

$$(\tau_{aBmax} = 240 N/mm^2)$$

$$F = 8,5 \text{ mm} \cdot \pi \cdot 1,5 \text{ mm} \cdot 240 N/mm^2$$

$$F = 9608,4 \text{ N} \sim 9,6 \text{ kN}$$

The required cutting force can be reduced by angled or serrated cutting.

Cutting clearance:

As a rule of thumb, it can be assumed that the cutting clearance should be 10% of the material thickness s . The W 14 tool system is supplied with a standard cutting clearance of 0.1 mm. The cutting clearance must be modified particularly in the case of soft materials, plastics and thin foils.

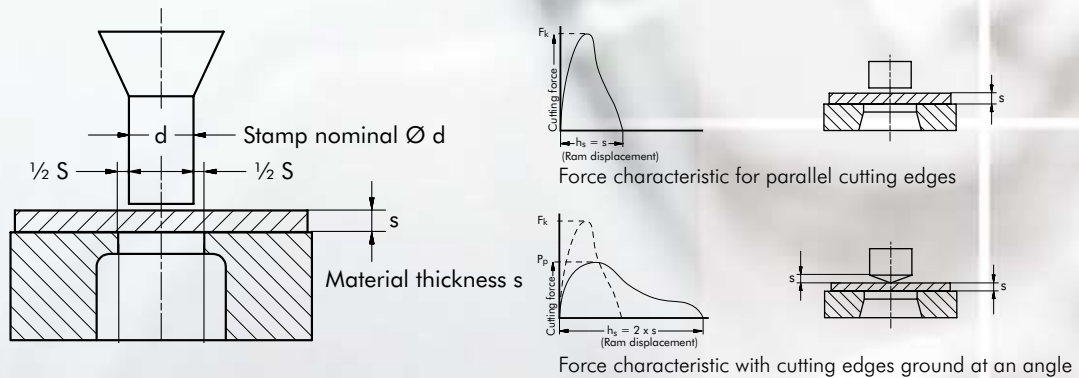

Selection of materials with shear strength τ_{aBmax} in N/mm^2					
Aluminium	Al 99 soft	60 - 80	Heat-treated steel	Ck 22	340 - 400
	Al 99 half-hard	60 - 100		Ck 35	400 - 480
Alu alloys	Al Mo 3 soft	150 - 200	Ck 45	480 - 580	
	Al Mg 5 soft	190 - 210	Ck 60	560 - 680	
	Al Mg 5 half-hard	200 - 240	Stainless steel	V2A	600 - 900
	Al Mg 7 soft	240 - 280	Spring steel, hard		800 - 1200
	Al Mg 7 half-hard	280 - 320	Brass	Ms 58	300 - 450
Fine steel sheet	T St 10	220 - 400	Copper	Cu	200 - 230
	U St 12	220 - 340	Polyvinyl chloride, soft	PVC 1	20 - 180
	U St 14 2	80 - 320	Polyvinyl chloride, hard	PVC	160 - 250
Structural steel	St 37	300 - 360	Epoxy (print material)		180 - 300
	St 50	400 - 480	Laminated paper		70 - 90
	St 60	480 - 580			
	St 70	560 - 680			

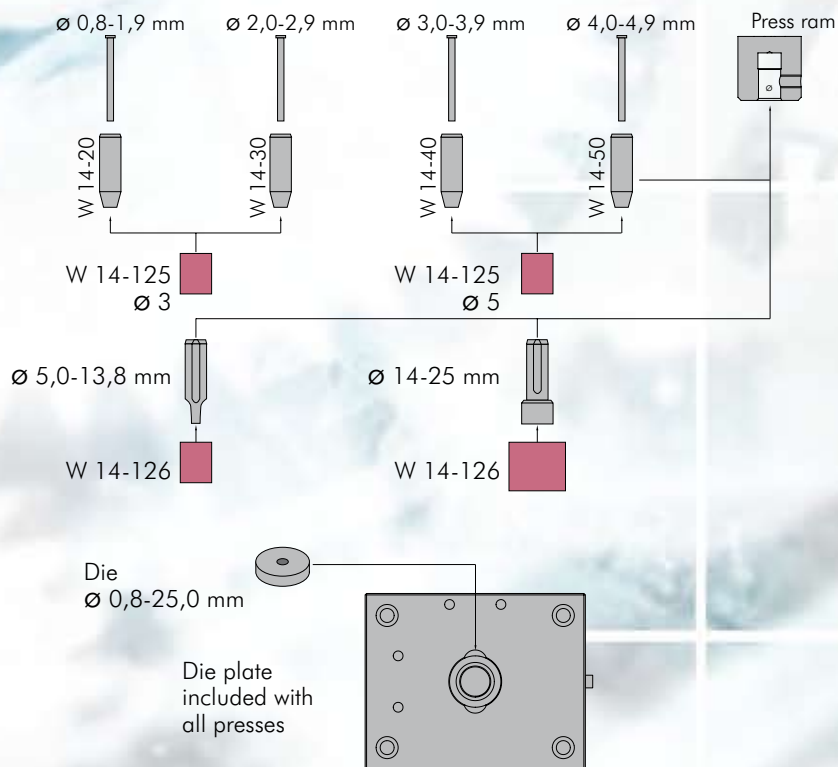

Round hole tools $\varnothing 0,8 - 5$ mm

	$\varnothing 0,8 - 1,9$	$\varnothing 2,0 - 2,9$	$\varnothing 3,0 - 3,9$	$\varnothing 4,0 - 4,9$
	stamp step grade 0,1 mm W 14-298 to W 14-215	stamp step grade 0,1 mm W 14-316 to W 14-325	stamp step grade 0,1 mm W 14-426 to W 14-425	stamp step grade 0,1 mm W 14-536 to W 14-550
	reduction sleeve W 14-20	reduction sleeve W 14-30	reduction sleeve W 14-40	reduction sleeve W 14-50
	stripper W 14-125 $\varnothing 3$	stripper W 14-125 $\varnothing 3$	stripper W 14-125 $\varnothing 5$	stripper W 14-125 $\varnothing 5$
	die W 14-3508 to W 14-3515	die W 14-3516 to W 14-3525	die W 14-3526 to W 14-3535	die W 14-3536 to W 14-3550

Round hole tools $\varnothing 5 - 13,8$ mm

	stamp step grade 0,0/0,2/0,5/0,8 W 14-1450 (5,0) to W 14-14138 (13,8)
	stripper W 14-126 red (spring range 33%) W 14-126 brown (spring range 20%)
	die W 14-3550 bis W 14-35138

Round hole tools $\varnothing 14 - 25$ mm

	stamp step grade 0,0/0,2/0,5/0,8 W 14-1450 (5,0) to W 14-14138 (13,8)
	stripper W 14-126 red (spring range 33%) W 14-126 brown (spring range 20%)
	die W 14-3550 to W 14-35138

Slot cutting fittings

	stamp step grade 0,0/0,2/0,5/0,8 W 14-1450 (5,0) to W 14-14138 (13,8)
	stripper W 14-126 red (spring range 33%) W 14-126 brown (spring range 20%)
	die W 14-3550 to W 14-35138

Square and rectangular cutting fittings

	stamp step grade 0,0/0,2/0,5/0,8 W 14-1450 (5,0) to W 14-14138 (13,8)
	stripper W 14-126 red (spring range 33%) W 14-126 brown (spring range 20%)
	die W 14-3550 to W 14-35138

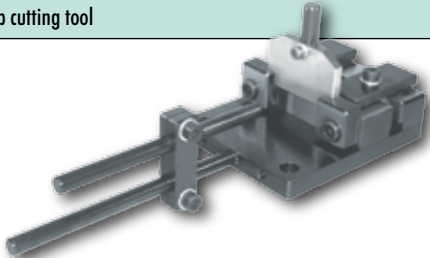
Strip cutting tool	
	up to 50 or 100 mm wide

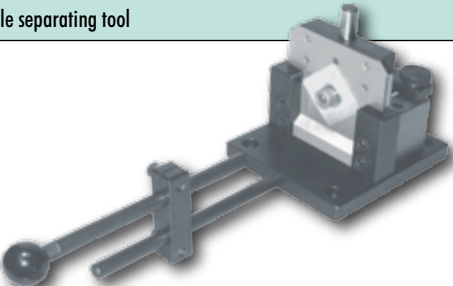
Angle separating tool	
	Relocatable separating stamp max. leg cut length 40 mm

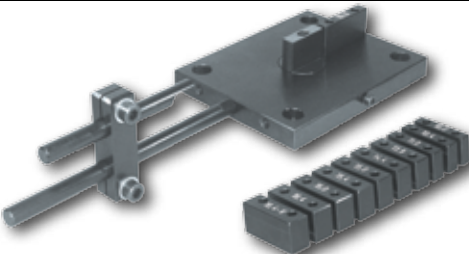
Profile rail punch with 10 plug-in centring inserts	
	Bar stop Stripper Die and stamp not included.

Profile separating tool	
	Base tool with separator plate insert Separator for NS 15 and NS 35/75 mounting rails, steel, in accordance with DIN EN 50045 and DIN EN 50022. Please specify profile shape when ordering.

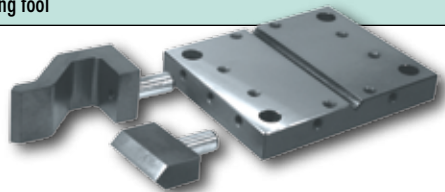
Bending tool	
	Standard bending 90° Special bending angles or bending forms to customers' requirements Overall width 60 mm or 120 mm. Please specify.

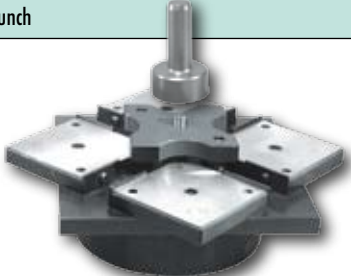
Rotatable radius punch	
	Tool for signs and front plate fabrication R3/5/8/10 or R5/10/15/20

90° notching tool

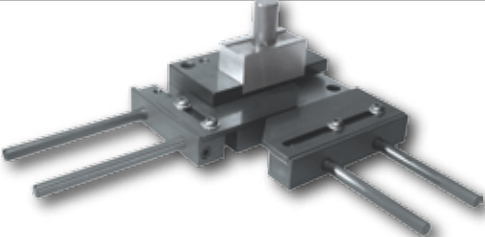
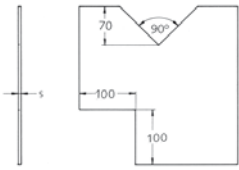
complete with adjustable swivel stops
For Alucobond processing
With 2 replaceable punches Ø 5.3

Combination corner punch

Complete with stops for 4 applications
Universal corner processing tool for Al / St / V2A

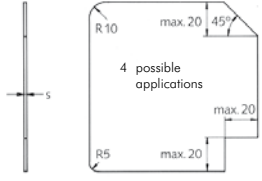
Standard stop, bar design Type: Z-100

X-axis 250 mm without scale
Y-axis 40 mm without scale

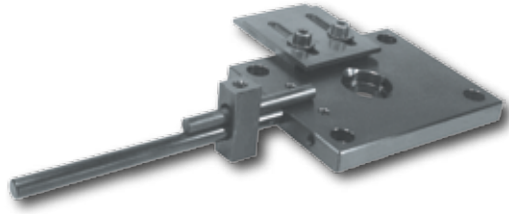
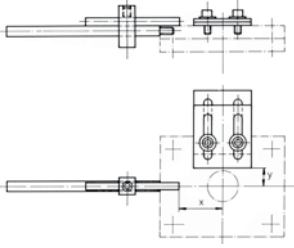
Standard stop, plate design Type: Z-101

X-axis 250 mm without scale
Y-axis 40 mm without scale

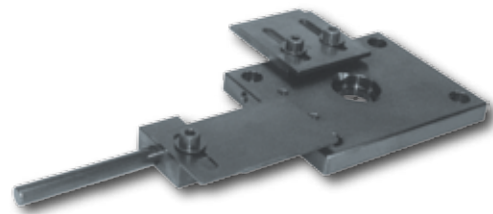
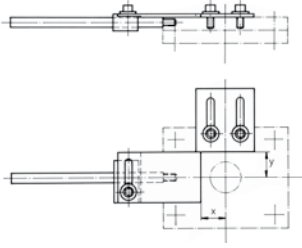
Coordinate stops

Nr. Z-102
Nr. Z-110-300
Nr. Z-120-520
Nr. Z-111-120
Nr. Z-121-255

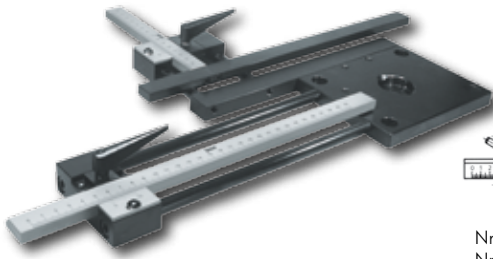
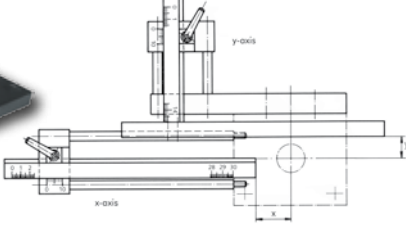
X-axis 300 mm Z-110-300
X-axis 520 mm Z-120-520
Y-axis 120 mm Z-111-120
Y-axis 255 mm Z-121-255

CONTACT

CONTACT

made in Germany by:

mäder
pressen

mäder pressen GmbH

Robert-Bosch-Str. 13

78579 Neuhausen ob Eck

Germany

Tel.: +49 (0) 74 67 - 94 67 - 0

Fax: +49 (0) 74 67 - 94 67 - 50

info@maederpressen.de

www.maederpressen.de

